

MAGURA

QM adapter INSTALLATION INSTRUCTIONS

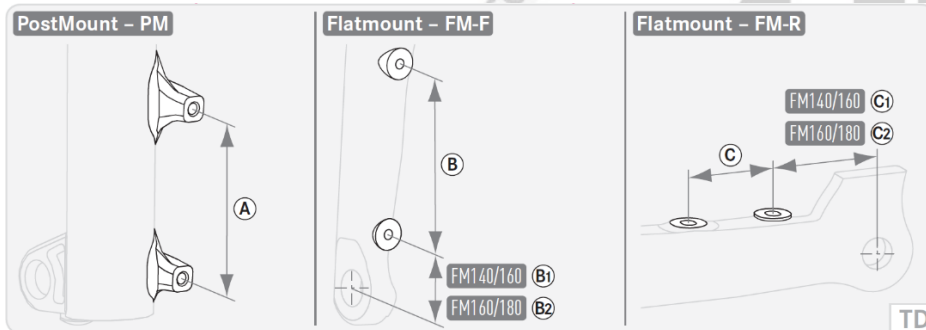
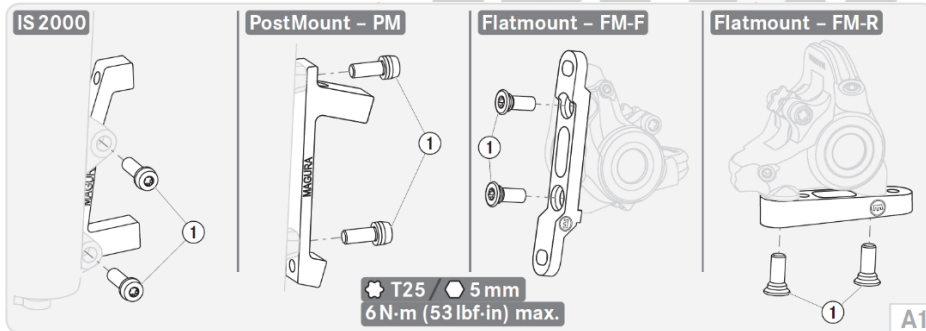
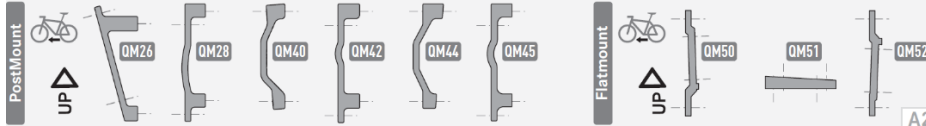
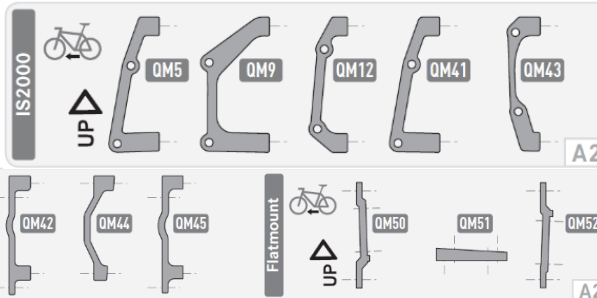

PREFACE

Follow the MAGURA *Owner's manual* – MT for your disc brake in addition to this installation instructions – www.magura.com !

WARNING ... warns you about a dangerous situation which can lead to serious or fatal injury if not avoided.

NOTICE ...warns you about the risk of material damage.

BASIC SAFETY INSTRUCTIONS

WARNING Danger of accident due to faulty or non-approved installation work.

- ⊙ Never overestimate your technical capabilities. Commission a specialist workshop for bicycles or a MAGURA service center with all installation work.
- ⊙ Never make changes to your MAGURA part.
- ⊙ Always observe all specified min./max. values.
- ⊙ Always use a suitable torque wrench.

WARNING Danger of accident due to component failure or sudden brake lock-up.

- ⊙ Install no more than 1 MAGURA QM adapter per brake caliper.

☞ Make sure that the mounting base is milled smooth, free from burrs and paint residues and are coated with corrosion protection.

☞ Make sure that your MAGURA QM adapter fits the disc brake rotor \varnothing and mounting base standard – see tables and [TD].

☞ Make sure that the retaining screws are always coated with fresh screwlock (medium strength) before installation.

ⓘ MAGURA QM adapters are generally fitted with an arrow – when installed the arrow must point upwards (UP). Overview shows the correct installation position of the QM adapter. [A2]

ⓘ **QM40 QM44** The adapter is screwed in combination with the brake caliper – see MAGURA *Owner's manual* – MT – the following installation step is therefore not required.

☞ Tighten retaining screws (1) with tightening torque of **6 N·m (53 lbf·in)**. [A1]

Installing QM adapter

		Ø 140 mm	Ø 160 mm	Ø 180 mm	Ø 203 mm	Ø 220 mm
Fork	IS 2000	—	QM43	QM12	QM5	—
	PM160	—	Direct mount	QM40	QM42	—
	PM180	—	—	Direct mount	QM26 QM44	QM45
	PM203	—	—	—	Direct mount	—
	PM220	—	—	—	—	Direct mount
	FM140/160	—	QM50	—	—	—
	FM160/180	—	QM52	QM50	—	—
Rear triangle	IS 2000	—	QM12	QM41	QM9	—
	PM140	Direct mount	QM40	QM28 QM45	—	—
	PM160	—	Direct mount	QM40	QM42	—
	PM180	—	—	Direct mount	QM26 QM44	QM45
	PM203	—	—	—	Direct mount	—
	PM220	—	—	—	—	Direct mount
	FM140/160	Direct mount	QM51	—	—	—
	FM160/180	—	Direct mount	QM51	—	—

[TD]		PostMount - PM	Flatmount - FM
Mounting base spacing	mm	74 ^{±0.1} [PM] (A)	70 ^{±0.1} [FM-F] (B) 23.5 ^{±0.1} (B1) · 32 ^{±0.1} (B2) 34 ^{±0.1} [FM-R] (C) 36.5 ^{±0.1} (C1) · 45 ^{±0.1} (C2)

Download the complete manual on www.magura.com

Specifications are subject to change without prior notice!

2600576 — 10.2019 ©MAGURA 2019 All rights reserved

①Check out our worldwide partners and service centers at www.magura.com

MAGURA GROUP GERMANY
MAGURA ASIA LIMITED CO .

www.magura.com
www.magura.com.tw

