

# 2019

## MOBILITY SOLUTIONS



BIKE  
PERFORMANCE COMPONENTS





Photo: Philip Rüppel





## ABOUT MAGURA 關於 MAGURA

4

125 YEARS OF MAGURA 125週年：MAGURA精進引領全球向前邁進	4
HIGHLIGHTS 專屬於你：年度「心」品亮相	10
MAGURA ORIGINAL SPARE PARTS 給最好用最好的：MAGURA原廠配件	12
MAGURA eCOMPETENCE 引領未來：MAGURA用知識打造新時代	14
MAGURA TECHNOLOGY 獨一無二：MAGURA全球獨家科技	16

## PRODUCTS 德國精品

18

PRODUCT OVERVIEW 2019年產品總覽	18
DISC BRAKES 安全守護：液壓碟煞	20
RIM BRAKES 經典鉅獻：液壓輪圈煞	30
S-PEDELEC BRAKES 解答未來：高速電動自行車煞車	36
DROPPER SEATPOST 全球首創：無線伸縮座桿	42

## TUNING PARTS 獨家絕配：你的個性化煞車

46

LEVER BLADES 我選我煞：拉柄	49
COVER-KITS 我選我煞：卡鉗環	50
HANDLEBAR CLAMPS 我選我煞：煞把固定環	51

## ORIGINAL SPARE PARTS 最佳支持：高品質原廠補修件

52

BRAKE PADS OVERVIEW 煞車塊與來令片總覽	55
BRAKE PADS 煞車塊與來令片	56
SERVICE PRODUCTS 維修保養產品	58

## APPAREL

潮炫酷型：MAGURA專屬人身部品

60

SPONSORED RIDERS 贊助運動員及車隊	66
ASIAN ATHLETES 亞洲贊助運動員	70
PRODUCT TABLE: BRAKES 產品列表：煞車	71





125 YEARS

1000

MAGURA PERFORMANCE COMPONENTS



# 125 YEARS OF MAGURA: A STORY OF SUCCESS

## 125週年：MAGURA 精進引領全球向前邁進

### 125 years of success

125 years of MAGURA history, from the gear rack for steering columns – still a symbol in the company's logo today – to the manufacture of state-of-the-art electronics and high-tech synthetic materials developed in-house. For decades now, MAGURA has been a reliable manufacturer for the motorcycle and bicycle industry and in recent years has been a driving force behind the new and cutting-edge e-mobility. Gustav Magenwirth, born in Bad Urach in 1866, would probably greet this development with a proud smile. He was known as an inventor and thinker who was always far ahead of his time. In his early years, he showed himself to be as flexible as MAGURA is today, on the occasion of its anniversary 125 years after it was founded.

An apprentice and later employee of Karl Benz, Magenwirth later became a manufacturer of engines, hydraulic pumps, synthetic materials as well as motorcycle & bicycle components. Gustav Magenwirth invented one of the milestones in the company's history, the straight-pull control lever blade for motorcycles, which led to a cooperation with BMW in the motorcycle sector that still exists today. The combination of tradition and progress at MAGURA is characterised by the fact that Gustav Magenwirth's family home is now used as the headquarters of the holding company MAGENWIRTH Technologies in Bad Urach.

Magenwirth, his wife Luise and their daughters Julie, Martha and Klara were always forward looking, even during difficult periods in the company's history, especially during the Great Depression of 1928 and in the years until the end of the Second World War. Their husbands and their sons, e.g. Eugen Munz and Werner Auch, also drove the company forward. Fabian Auch, great-grandson of Gustav Magenwirth, is now the fourth generation of the family to be represented in the company. MAGURA always thinks ahead, creating innovative ideas for e-mobility and continuously developing existing components such as an electronically-controlled seatpost and product collaborations with other companies of MAGENWIRTH Technologies.

### 125年的成功故事

成立至今125年的MAGURA擁有一部經典輝煌歷史，從象徵公司的轉向柱齒輪架，到現在製造最先進電子產品、內部開發的高科技複合材料，一直以來都是全球兩輪世界領導品牌，以及摩托車與自行車行業的可靠製造商。

這一切都和MAGURA創辦人Gustav Magenwirth(古斯塔夫·瑪耿威特)的大膽遠見及靈活個人特質不謀而合。Gustav Magenwirth在當時被喻為引領時代發展的發明家及思想家，於1866年出生於德國南方小鎮Bad Urach (烏拉赫)，對於MAGURA現今的發展狀況，他會以驕傲的微笑迎接。

曾是德國汽車大廠賓士(Mercedes Benz)液壓工程師的Gustav Magenwirth，喜愛透過鉛筆記錄、圖面化液壓產品，鉛筆筆蕊和線條勾勒著他的想法，腦中天馬行空的創意得以躍然紙上。隨後Gustav Magenwirth創辦MAGURA，發明摩托車用的直拉式控制桿拉柄，是公司發展的重要里程碑，Gustav Magenwirth的發明傑作，也開啟MAGURA與BMW雙方合作至今接近百年的佳話。結合傳統與未來進步，在MAGURA現今仍不斷發生，像是Gustav Magenwirth在Bad Urach的住宅，現也成為控股公司MAGENWIRTH Technologies的總部。

在125年的歲月中，MAGURA也曾面臨到1920年代經濟大蕭條及二次世界大戰等時代動盪，Gustav Magenwirth與他的妻子Luise、女兒Julie、Martha與Klara總是向前看。後續的接班人Eugen Munz和Werner Auch也推動公司向前發展，現在Gustav Magenwirth的曾孫Fabian Auch已開始擘畫未來。早年MAGURA有句口號“MAGURA, always a step ahead” (瑪古拉，永遠領先一步)，這不僅是句口號，更是公司最佳行動註解，MAGURA始終在思考未來，為電動移動載具創造新的理念，並不斷與MAGENWIRTH Technologies控股公司旗下公司合作開發，引領人們突破現在既有框架。

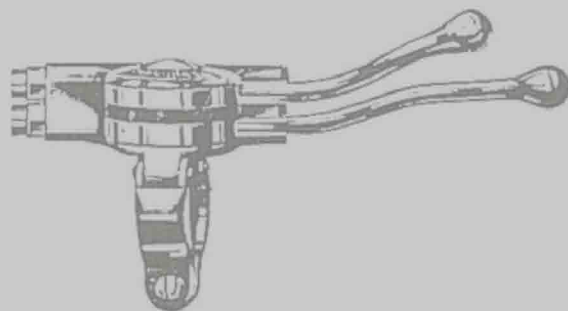

1893  
2018





Photo: MAGURA



Photo: MAGURA

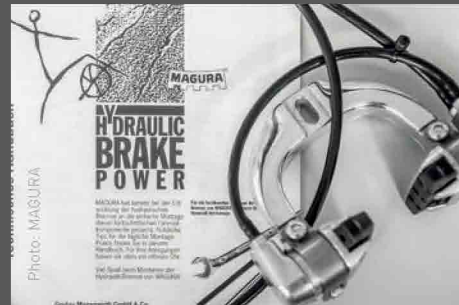

Photo: MAGURA

### 設計讓性能再進化

1957年，MAGURA併購一家合成材料公司，以開發自己的產品和精緻設計。如今，高品質的德國精品MAGURA，在位於總部Bad Urach附近Hülben（許爾本）擁有先進工廠生產，獨家科技Carbotecture®和CarbotectureSL®材料也在內部開發和製造。位於在Hengen（韓根）的工廠也有130名員工生產自行車煞車、摩托車零部件和工業零件。瑪古拉亞洲（MAGURA ASIA）於2002年成立於台灣台中市，為德商MAGURA 瑪古拉企業集團在亞洲地區唯一的子公司。為了服務亞洲地區高端自行車組裝廠的需求，自2011年起，於台中工業區設立MAGURA在德國境外唯一的產品生產線，以MAGURA先進、嚴苛的生產管理標準，投入組裝避震器及油壓碟煞系列產品，並行銷至全世界。2013年成功導入並通過ISO9001品質管理標準。另外姐妹公司Bebro electronics距離總部Bad Urach不到半小時的車程，提供電子組件，設備和系統的技术知識。

MAGURA 現在將其業務活動分為四個重要部分：Bike, Powersports, Controls和Composite。在進入自行車領域30年的歲月，MAGURA不斷創造全新的里程碑。1987年開發出全球第一個專為自行車設計的液壓煞車Hydro-Stop (HS液壓輪圈煞車)，從自行車產業的新進者變成技術領導者，產品的高科技部件採用內部開發和生產的材料製造，並且成功應用於現今深獲全世界車友喜愛的MT系列液壓碟煞。2013年MAGURA結合科技，創新推出全球第一支電子調整避震前叉eLECT，並且於2016年首創全球第一款無線升縮座管VYRON eLECT，在自行車產業不斷樹立全新標準，同時帶領自行車走向全新發展。

Photo: Philip Ruopp



## The performance has been redesigned

In 1957, MAGURA took over a synthetic materials injection moulding shop for the development of its own products and sophisticated designs. Today MAGURA produces in the state-of-the-art factory in Hülben, near Bad Urach, where the Carbotecture® and Carbotecture SL® materials are developed and manufactured in-house. At the Hengen plant, 130 employees produce bicycle brakes, motorcycle components and industrial parts. In addition, our products are also manufactured in Taiwan to ensure short delivery times to the manufacturers on site. Our Sister company Bebro electronics is less than half an hour's drive from Bad Urach and provides the technical know-how for electronic assemblies, devices and systems.

MAGURA now divides its business activities into four important segments: Bike, Powersports,

Controls and Composite. Over the last 30 years, MAGURA has transformed itself from a newcomer in the bike sector with the development of the first hydraulic bicycle brakes in 1987 to a technology leader in the industry. High-tech components are manufactured from materials developed and produced in-house and are successfully used in the test winner brakes of the MT series. Historical milestones included innovations like the first electronic suspension fork adjustment 'eLECT', which was presented as a world innovation in 2013. In recent years, MAGURA has increasingly been involved in the electrification of the bike sector. In 2016, the world's first wirelessly adjustable seatpost – the VYRON eLECT – set new standards, becoming a highly successful product on the cycle market.

# PASSION & INNOVATION

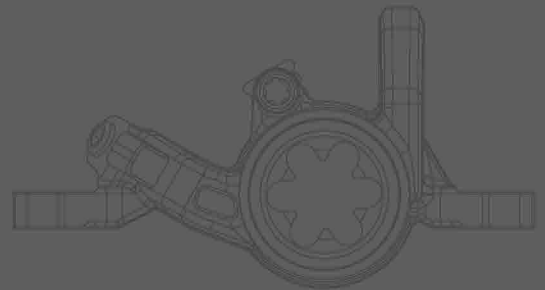



## Worldwide on the road to success

For years now MAGURA has been successfully expanding in the motorcycle and bicycle industry. The company is represented worldwide by its subsidiaries in the USA and Asia. MAGURA has also been a service partner for Bosch e-bike components and drive units from the outset. In addition to providing telephone advice to specialist dealers and organising specialist dealer training courses, MAGURA handles all service cases for its partner Bosch in one of four European MAGURA service centres. This long-standing cooperation led to the development of the first ABS disc brake for bicycles, which was presented to the public in 2017. Since 2017, MAGURA, ZF Friedrichshafen and other companies have combined their strengths

in a joint venture to promote e-mobility, providing technological impetus in a key future market. The common goal is to develop, manufacture and sell products for the growing e-mobility market.

In the coming years, this traditional company will continue to focus on the future. MAGURA's 125th anniversary year is being celebrated in a way that also benefits the company's customers – an anniversary brake has been produced as a special edition in elegant wooden packaging. With the anniversary logo engraved on the master and caliper, the MT1893 brake model sets new accents for the anniversary. Genuine MAGURA fans, dealers and bike enthusiasts shouldn't let this eye-catcher pass them by!

Photo: Bosch

RATIO ADJUST 煞車槓桿比率可調整

4-PISTON BRAKING POWER

屢獲殊榮的4活塞煞車制動性能

LIMITED EDITION 全球限量發行



## MT1893

The MT1893, a special limited edition, offers full 4-piston braking power and can be adjusted individually with the HC3 lever blade. Its chrome design and 12 coloured covers make it a real eye-catcher.

全球限量發行的MT1893，擁有MAGURA頂尖的獨家技術，4活塞制動力讓你在艱難的Enduro和下坡賽道，獲得所需的精確控制和最大穩定性。與「街攀大師」Danny MacAskill共同開發的HC3拉柄，可輕鬆單獨調整握距及煞車力道。卡鉗採用鍍鉻設計，刻有創始年份1893標識和序號，使用者透過卡鉗環打造你最獨特的個人標誌。

Weight 重量	245 g
Master 煞車本體材質	Carbotecture SL® 高科技碳纖維複合材質
Lever blade 煞車拉柄	1-Finger HC3, Aluminium 鋁合金單指HC3拉柄
Reach adjust 握距調整	3 mm allen key 3mm內六角扳手
Ratio Adjust 煞車桿桿比率調整	T25 tool T25工具
Pistons 活塞	4
RRP 建議售價	499,90 €
Order No. 產品編號	2 701 780

without rotor/adaptor 不含碟盤/轉接座

# A TRULY HISTORIC BRAKE



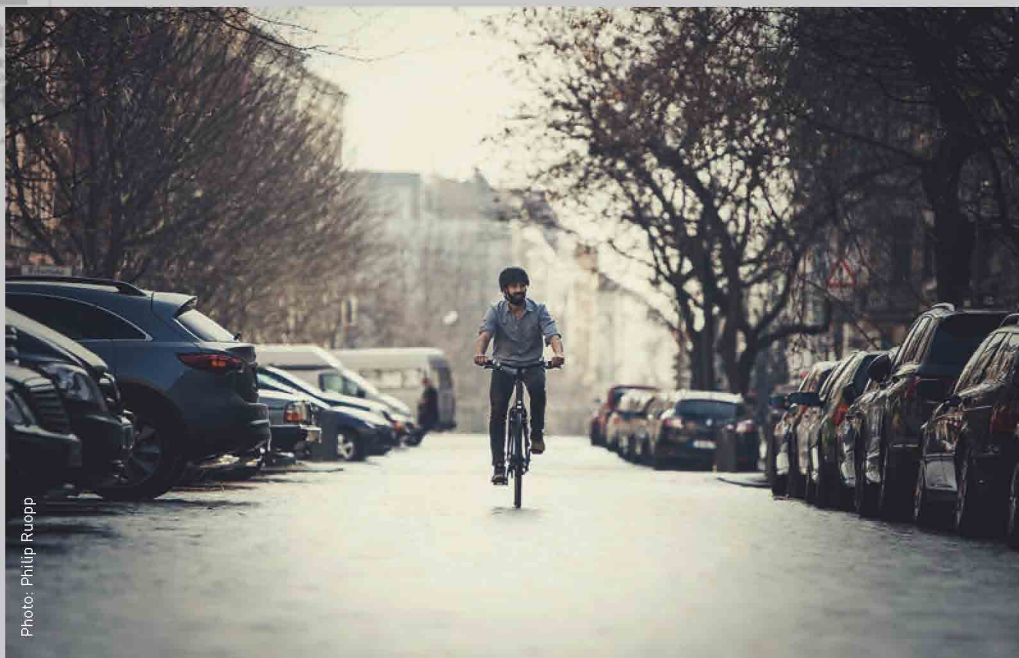

### 於全世界走在成功道路上

MAGURA於全球兩輪產業(摩托車與自行車)拓展成功多年，同時在美國及台灣設有據點。近來發展興盛的電動自行車，MAGURA已深耕多年，除了提供質量均優的產品，並且也是Bosch(博世)在電動自行車零件和驅動裝置的服務合作夥伴，擁有專業知識的MAGURA，提供經銷商諮詢解決方案，也進行專業經銷商培訓課程，雙方自1950年代開始長期合作至今，促成全世界第一款電動自行車專用的ABS碟煞開發，並於2017年公開問市。

此外MAGURA也在2017年與德國知名ZF Friedrichshafen及其他公司合作，多方把互相優勢結合一起，開發持續成長的電動車市場是共同目標，並且促進電動載具及提供未來關鍵市場技術動力，這是未來幾年MAGURA關注的方向。

擁有良好傳統，持續不斷關注未來，MAGURA走過125年歲月，用最特別的方式留下紀念，結合MAGURA最佳科技的MT1893限量問市，同時附上精美木盒包裝，MAGURA也在卡鉗刻上1893紀念標誌，並且全球限量發售1893套，是喜愛MAGURA的車友、經銷商及自行車愛好者們，值得擁有的傳家珍寶。



# HIGHLIGHTS THIS IS NEW

## 專屬於你：年度「心」品亮相

→ S. 57

### No worries about retrofitting s-pedelecs

Innovation is not an end in itself, it means arduous work in minute detail – such as the fulfilment of standards and guidelines that MAGURA products have achieved in the brake sector.

At the end of 2017, the MAGURA Storm HC rotor became the first bicycle rotor ever to be given a National Type Approval (ABE), exemplified in the laser-engraved 'KBA-number'. With this approval, the MAGURA Storm HC rotors can be retrofitted on a s-pedelec in a simple and smooth procedure by the consumer or dealer, provided that the bicycle model is listed on the type list. Until now, only an absolutely identical component could be used. This means that the dealer needs to have only one rotor brand available – and the cyclist has a compatible and certified spare part. Meaning a visit to the German Technical Inspection Authority (TÜV) testing procedures is no longer necessary. Since May 2018 selected brake masters and calipers from MAGURA have as well a National Type Approval.

jetzt mit  
**ABE**



KBA-certified

This was echoed by the ECE standard for MAGURA Performance and Comfort brake pads – issued for the first time on the market. Instead of stocking up on brake pads from the same series, dealers and consumers can now obtain certified MAGURA brake pads – meaning that they're always on the safe side with MAGURA Original Spare Parts.

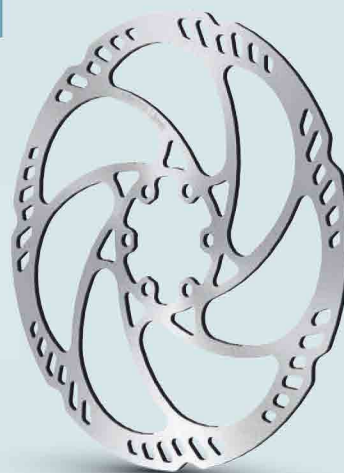

### 升級改裝免擔心：高速電動車

創新並非本身主要目的，把細節更做得更完美精進，是MAGURA在制動領域的標準方針。安全第一！MAGURA風暴.HC碟盤在2017年底寫下新里程碑，是首款經德國聯邦KBA批准獲得德國國家認證（ABE）的碟盤，使用者可以安裝所有被批准的高速電動自行車上，這意味著騎乘者在德國更換碟盤時，不需要再經過德國技術監督協會（TÜV）的測試程序，而且自2018年5月開始，MAGURA的煞車及卡鉗，也獲得德國國家認證。

這與符合歐盟法規(ECE)的MAGURA Performance和Comfort來令片相互呼應，經過認證的MAGURA來令片，對於經銷商與消費者是一大佳音，意味使用MAGURA原廠產品及配件，極具安全認可。



→ S. 28

### New flatmount brake

Flatmount, a development from the road bicycle sector, now also benefits the mountain bike sector. Thanks to their compact design, flatmounts can also be installed on lightweight frames with the relevant mounting attachments. Rotor diameters of up to 160 mm are possible, and the standard sizes of pistons and brake pads have been retained, so that original MAGURA brake pads can also be used for the flatmount brake. This is a clear advantage for the trade and end consumer – typical MAGURA!

### 貼心出擊：全新平裝式卡鉗

貼近使用者需求，現在騎乘登山車也可以使用平裝式卡鉗！擁有更緊湊扁平設計，平裝式卡鉗可安裝在輕量化車架上，碟盤最大可相容至160mm，同時MAGURA在活塞及來令片保留標準尺寸，方便使用者們更換。絕佳功能、超方便性，平裝式卡鉗帶給你快意享受德國精品MAGURA的魅力。



→ S.46

### Customize your brake

Customize with colour – the new MAGURA brake calipers are getting more colourful! In addition to the classic blue, neon red and neon yellow colours for the tuning rings, there are now new colours from the bike industry, like mint, cyan and purple. With its four new sets, MAGURA offers the right colour for every customiser. Need more tuning parts? You'll find them from page 46 onwards in the catalogue.

### 心光閃靚：點亮你的個性化煞車

顏色由你來定義，MAGURA煞車卡鉗越來越豐富多彩！卡鉗環不僅擁有經典藍、霓虹紅及霓虹黃，現在更有深受歡迎的薄荷綠、青綠色及魔幻紫。

MAGURA提供四個組合，讓使用者可選擇適合你的顏色，想要了解更多？速速前往型錄第46頁。



### 1-Finger HC carbon lever blade

The popular 1-finger HC lever blade is now also available as a carbon version. The lever blade has a comfortable feel and the high-tech material carbon combines ultra-light weight and rigidity, clear benefits for riders. The HC Carbon lever blade can be retrofitted to brake models with Carbotecture SL® housings (MT6, MT7, MT8 and MT TRAIL CARBON). The lever blade is already fitted as standard on the MT8 SL and MT TRAIL SL from model year 2019.

### 單指HC碳纖維拉柄

擁有舒適手感特點的單指HC拉柄，深受車友們喜愛。現在MAGURA提供結合高科技材料、超輕量化及剛性的HC Carbon拉柄。為使用者帶來明顯益處的HC Carbon拉柄，可改裝於本體為CarbotectureSL®材質的煞車，如：MT6、MT7、MT8及MT TRAIL CARBON。自2019年開始，HC Carbon拉柄也是MT8 SL及MT TRAIL SL的標準配備。

→ S. 49

## STAY CONNECTED!

### MAGURA News

To make it really convenient for everybody to be well informed, we post updates on our website, Facebook and Instagram.

### MAGURA 訊息

時時刻刻了解MAGURA最新動態，請隨時在瑪古拉網站、社群網站掌握最新訊息。

→  [magura.com](http://magura.com)

→  [facebook.com/magurapassionpeople](https://facebook.com/magurapassionpeople)

→  [instagram.com/magura\\_official](https://instagram.com/magura_official)



# MAGURA ORIGINAL SPARE PARTS 給最好用最好的： MAGURA原廠配件

Service and quality – MAGURA Original Spare Parts mean not only swabian quality you can rely on, but also excellent service: All products are repaired in one of the four European MAGURA service centres as well as at our subsidiaries in the US and Asia. Who else is able to repair important components such as brakes and suspension forks and to restore them to top condition better than our in-house experts?

MAGURA Original Spare Parts are always available, so you can rely on the brakes even after years of use. Our spare and wear parts guarantee maximum performance and safety. The range includes rotors in all common sizes, and brake pads for every use from comfort and performance to racing. Replacing worn MT series brake pads is oh-so-easy thanks to the MAGURA magnetiXchange system.

MAGURA's choice of materials is also oriented on reliability – and this is why all hydraulic braking systems from MAGURA use mineral oil – the renowned MAGURA Royal Blood. Its biggest advantage? Royal Blood does not age or draw water, and in contrast to DOT brake fluids, it doesn't have to be periodically bled off and refilled. Royal Blood also does not damage paintwork or materials.

服務和品質！使用MAGURA原廠配件，不僅意味著你信賴來自德國施瓦本地區的高品質，還意味著享有優質服務。所有原廠配件均可在MAGURA歐洲四大服務中心，以及瑪古拉亞洲(MAGURA ASIA)和瑪古拉美國(MAGURA USA)行維修保養，搭載使用原廠配件的煞車及避震器，也能享有維修服務，讓最專業的MAGURA技師們，提供給您前所未有的非凡騎乘享受。原廠配件提供產品最高性能及安全性，包含各式型號尺寸的碟盤，以及舒適型、功效型及競賽型來令片。

MT系列煞車來令片更換輕鬆方便，全歸功於MAGURA獨家的magnetiXchange(磁吸式來令片技術)貼心設計，讓磨損的來令片可在幾秒鐘內快速輕鬆更換。

可靠性是MAGURA在材料選擇的首要考量，這也說明為什麼MAGURA的所有液壓煞車系統均使用礦物油，著名的MAGURA皇家血統礦物油，擁有無毒且自帶潤滑效果，並有不溶於水、不氧化的特性。

皇家血統礦物油的化學與物理性穩定，可延長液壓煞車使用壽命，不會損壞車漆或其他材料，也不會傷害人體的皮膚，讓車友們在DIY時換油更方便。

# BEST PARTS = BEST BRAKING PERFORMANCE

## MAXIMUM BRAKING POWER

You'll get maximum braking power using original MAGURA rotors and brake pads – because our components are optimally matched to each other in terms of material and technology.

## CONSISTENT QUALITY

All MAGURA Original Spare Parts are subject to constant quality controls and ensuring consistently high quality.

## 5 YEARS GUARANTEE

MAGURA offers a five-year leak proof guarantee on all calipers and masters, provided they are exclusively equipped with MAGURA Original Spare Parts.

## 最大制動力

使用MAGURA原廠碟盤及來令片，你將獲得最大製動力，所有配件在材料及獨家科技獲得最佳匹配。

## 始終如一的高品質

所有MAGURA原廠零配件系列，出廠前都經過品質控管，確保你使用的產品是最佳品質。

## 五年防漏保固

MAGURA提供合法購買證明之第一手買主（須提供購買證明）獨家煞車五年防漏保固，期限自購買日起五年內有效。只要你使用MAGURA原廠配件（不得混用他牌），所有煞車卡鉗及煞車把手提供五年防漏油保固（不包含煞車油管）。





Photo: Philip Ruopp







# MAGURA eCOMPETENCE

## BRAKE KNOWLEDGE FOR A NEW ERA

### 引領未來：MAGURA用知識技術打造新時代



#### MAGURA eCompetence

E-mobility is not a short-lived trend, it's a new mass movement. The car stands more and more staying in the garage, it's the e-bike that's being used for shopping and other errands. The e-bike market is growing continuously. MAGURA was and is still a competent part and engine of this development.

For all the brake system, especially for the heavier and faster bikes, MAGURA can rely on its over 90 years of experience in developing brake and clutch systems for motorbikes. The key points are maximum reliability and effective deceleration even for larger weights – criteria that clearly speak for MAGURA brakes. MAGURA has been scoring highly in magazine tests for years.

With the MT5e, MT4e and HS33e brake systems specially developed for s-pedelects, MAGURA offers a level of safety that has long been standard in the automotive industry. An integrated switch activates the brake light before the braking action occurs, so that it effectively warns following road users as well as switching the drive unit off during the braking process (depending on the drive unit manufacturer).

The importance of e-mobility for MAGURA is shown by the company's numerous innovations and products in recent years. Together with Bosch, the first ABS system for bicycle brakes was developed, and it has been available on the market since 2018. Bosch supplies the control system, MAGURA the know-how and technology for the brakes. Thanks to the first production-ready ABS, more controlled and stable braking is now possible even under the most difficult conditions, so the probability of going over the handlebar or the front wheel skidding away during a sudden braking manoeuvre is reduced to an absolute minimum.

Meeting safety standards is at the heart of MAGURA's brand. Our Storm HC rotor received a General Operating Permit (ABE) at the end of 2017. Since May 2018 selected brake masters and calipers from MAGURA have as well a National Type Approval. MAGURA Performance and Comfort brake pads have also complied with ECE directives since 2018. The brake pads and rotors can be smoothly and easily replaced in S-pedelects, thanks to the ECE directive and the ABE. MAGURA's compliance with these guidelines effectively means that the rider is spared a trip to the German Technical Inspection Authority (TÜV) and the dealer is on the safe side of the law.

#### MAGURA的電動自行車能力

電動載具絕不是短暫趨勢，而是未來發展的主流，電動自行車發展蓬勃，方便人們通勤購物，因此汽車停留在車庫的時間越來越長，MAGURA一直以來都是電動自行車發展的主要推手。

在摩托車煞車及離合器系統開發擁有近百年經驗的MAGURA，從摩托車高可靠、高品質的最佳減速技術，成功轉移至電動自行車上，多年來深獲業界喜愛，並獲得眾多媒體極高評價。

標準，擁有可斷電系統及煞車警示燈功能，以便有效警告後方用路人及關閉驅動元件（此功能取決於驅動元件製造商）。

MAGURA近針對電動自行車推出多項創新技術及產品，與Bosch一同開發全球首個專為電動自行車設計的ABS煞車，於2018年開始在市場銷售。MAGURA煞車的技術及知識搭配Bosch的控制系統，「雙強合作」帶給騎乘者絕佳安全騎乘感受，在緊急條件下，能提供穩定制動功能及對車子可控制性，減少前輪打滑及翻車可能性。符合安全標準是MAGURA品牌核心。風暴HC碟盤在2017年底獲得ABE認證，自2018年5月起，MAGURA煞車本體和卡鉗也獲得了德國聯邦的國家認證，此外MAGURA功能型來令片及舒適型來令片，也符合歐盟ECE法令。獲得ECE及ABE法令認可，使用者們可以在高速電動自行車安心更換MAGURA的碟盤及來令片，對於使用者及經銷商都是安全的絕佳保證。

# MAGURA TECHNOLOGY

## MAGURA technology – materials

As a manufacturer in the motorcycle and bicycle sectors, MAGURA is synonymous with quality and reliability. This is achieved through our own production in Germany. Since our production and assembly sites in Hülben and Hengen are located in the immediate vicinity of our Bad Urach headquarters, we have an extremely effective quality assurance system. This quality is always ensured during the production of all components in Taiwan.

With the development of our special materials and processes such as Carbotecture® and Carbolay®, we have realized designs and constructions that no other manufacturer can implement. To simply call these materials plastics would not give credit to the creative engineering effort behind these innovative developments.

Our materials are lightweight, extremely stable and remain reliable over many years. We achieve this with our own high-tech compounds and processing methods:

## MAGURA科技 – 無人取代的頂級材料

作為全球兩輪世界的領導品牌及製造商，MAGURA是高品質及可靠性的代名詞。能擁有全球頂尖成就，歸功於MAGURA在德國Hülben和Hengen兩座工廠，同時MAGURA在台灣設立位在德國海外生產線，所有的用料、部件在生產過程中，保有相同品質及可靠，讓你使用的MAGURA產品，均在全球兩輪產業樹立最高嚴格標準。

隨著Carbotecture®和Carbolay®等特殊材料和工藝的發展，MAGURA達到了其他製造商無法實現的設計和結構，創新且具創造性的高科技複合材料，擁有輕、強、美特點。

MAGURA的高科技複合材料，多年來累積的可靠性，讓MAGURA的產品更具獨特性，歡迎你體驗MAGURA在全世界的獨一無二！





# 獨一無二：MAGURA全球獨家科技

## CARBOTECTURE®

- Synthetic granules made of high-tech polymers and short carbon or glass fibres
- Any desired shape can be achieved thanks to the Carboflow process
- Complex shapes with smooth surfaces can be created
- 50% lighter than aluminium, with identical tensile and breaking strength

## CARBOTECTURE SL®

- An enhanced development of Carbotecture®
- Integration of medium-length carbon fibres
- Additional weight reduction with a level of resistance that has been increased yet again

## CARBOLAY® PROCESS

- Load-appropriate positioning of carbon fibres using a textile process
- Fully-automatic production without the usual manual work associated with carbon
- High rigidity of the components combined with low weight

## 獨家纖維複合材質

- 高科技聚合物，由短碳纖維或玻璃纖維製成的合成顆粒。
- 借助Carboflow工藝，可以實現任何所需的形狀。
- 可以創建具有光滑表面的複雜形狀。
- 比鋁輕50%，具有相同的拉伸強度和斷裂強度。

## 高科技碳纖維複合材質

- Carbotecture®的增強開發
- 中長碳纖維整合
- 重量更輕盈且強度再升級

## CARBOLAY®工藝

- 使用紡織工藝讓碳纖維編織更適當
- 全自動生產，無需經過碳纖維相關的常規手工步驟，降低人為錯誤機率
- 重量輕高剛性特點

# PRODUCT OVERVIEW

2019

## 2019年產品總覽

PRO

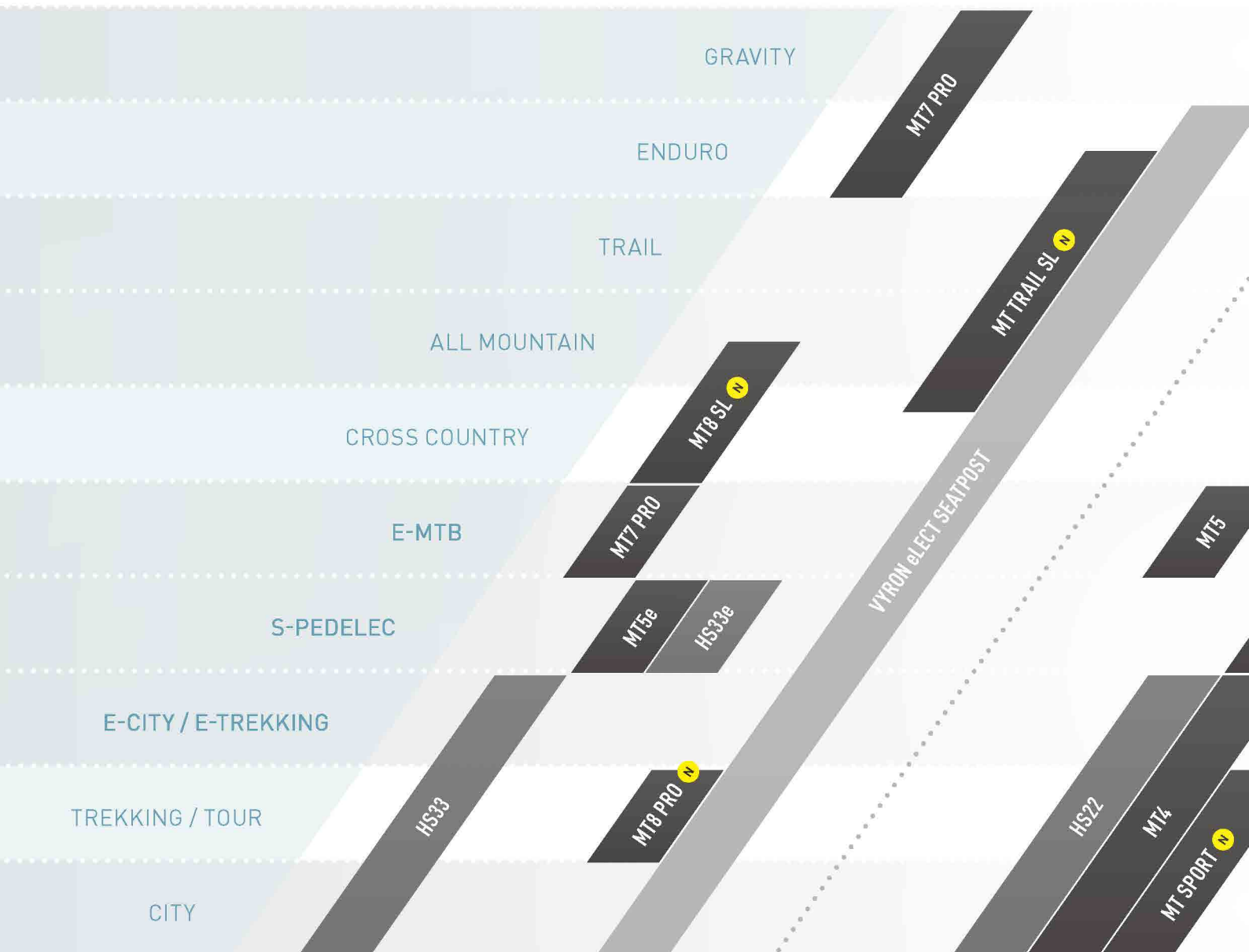

### MAGURA Product Overview 2019

Ranging from brakes for all types of bicycles to seatposts and e-mobility, MAGURA has a comprehensive and constantly growing product portfolio covering riding safety, comfort and innovative e-solutions. MAGURA products appeal to sporty and professional riders, as well as everyday cyclists and bicycle enthusiasts. MAGURA offers the right product for every type of cycling, from city, trekking and e-bike to cross-country and downhill. The product assignment in the Basic – Advanced – Pro categories shows every cyclist the right product at a glance.

New equipment, proven technology: The test-winning brakes in our MT series have been extensively upgraded. We have used new model names to create a better overview of the product categories and offer more choice to dedicated mountain bikers. The 1-finger HC carbon lever blade is installed on all SL (Super Light) brake models. The Pro models are equipped with the 1-finger HC lever blade in aluminium. All models with the 'SPORT' suffix are the powerful entry-level models in the MT brake family.

Explanation of product description:

SL = 1-finger HC carbon lever blade; PRO = 1-finger HC aluminium lever blade



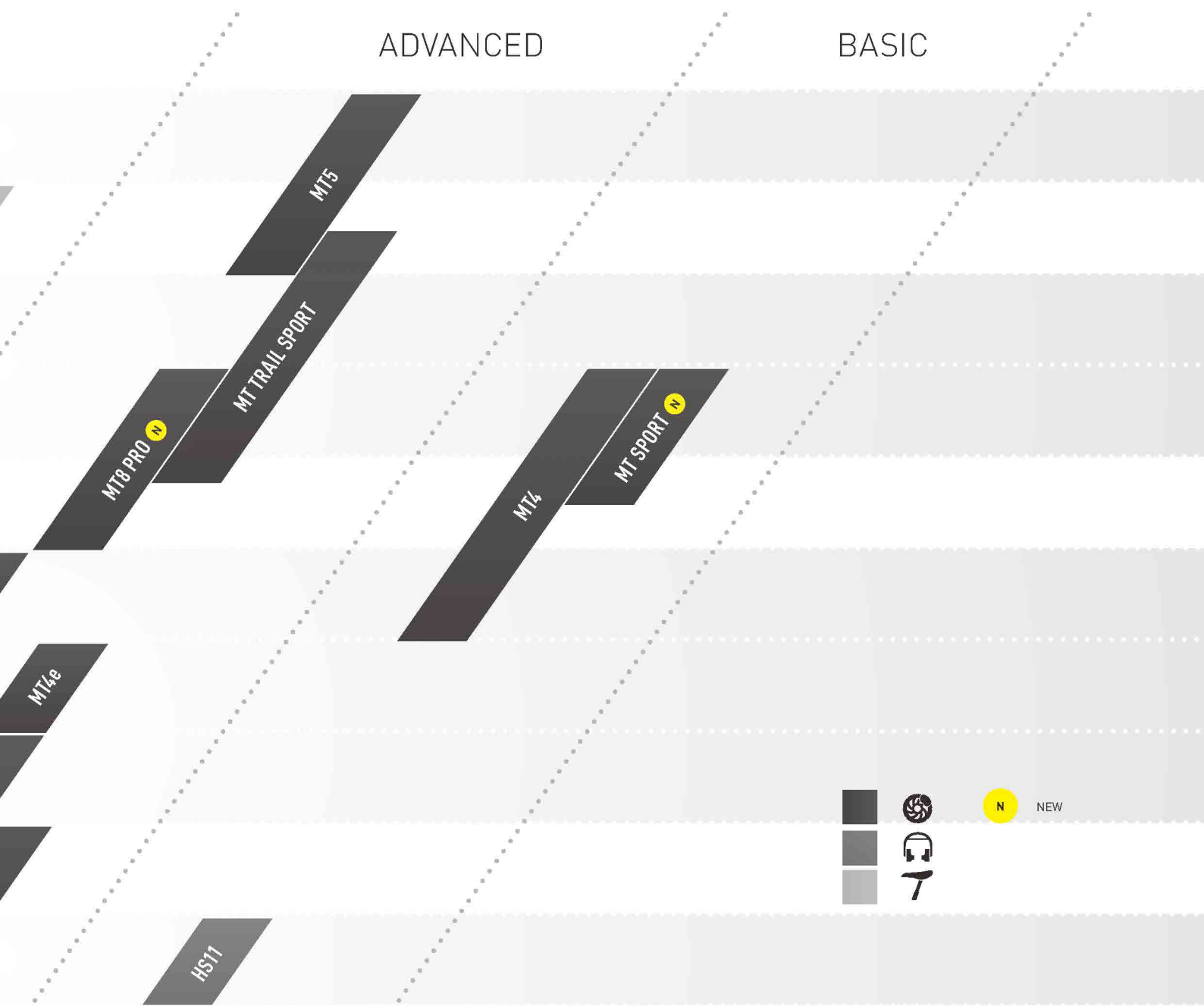

### 德國精品MAGURA 2019年新品

MAGURA擁有全面且持續發展的產品，從各類型的自行車煞車、伸縮座桿及電動自行車專用產品，提供使用者安全性、舒適性及創新的電動自行車解決方案，吸引專業車手、熱愛自行車運動人們喜愛，更符日常通勤及自行車愛好者們需求，無論是城市車、Trekking bike、電動自行車、越野車或是下坡車，在此都能找到符合你從入門、進階到頂級需求。

成熟技術讓MT系列煞車不斷進化，今年MAGURA使用新的型號名稱，更貼切敘述產品，並且提供給登山車友更多選擇。所有SL (Super Light) 型號的MT系列煞車均搭載單指HC碳纖維拉柄，Pro型號搭配單指鋁製拉柄，所有具備SPORT型號的煞車，即是代表該種類MT煞車的最佳入門款。

#### 產品說明

SL = 1指HC碳纖維拉柄；PRO = 1指HC鋁製拉柄







# DISC BRAKES

# DISC BRAKES MT TECHNOLOGY MT液壓碟煞科技



## 1 EASY BLEED TECHNOLOGY (EBT)

### 易注油技術

Quick and easy bleeding

注油作業快速簡單方便

## 2 BITE ADJUST TECHNOLOGY

### 煞車靈敏度調整技術

Toolless bite adjust

免工具即能進行煞車靈敏度調整

## 3 TOOL-LESS REACH ADJUSTMENT

### 免工具握距調整技術

Toolless reach adjust

免工具即可進行握距調整

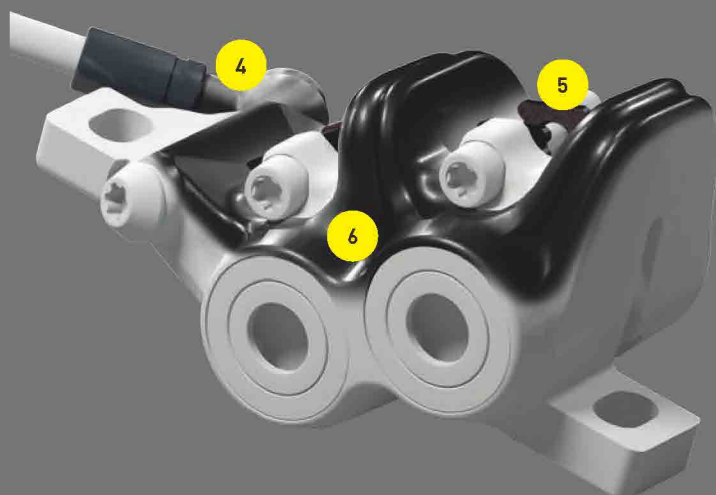
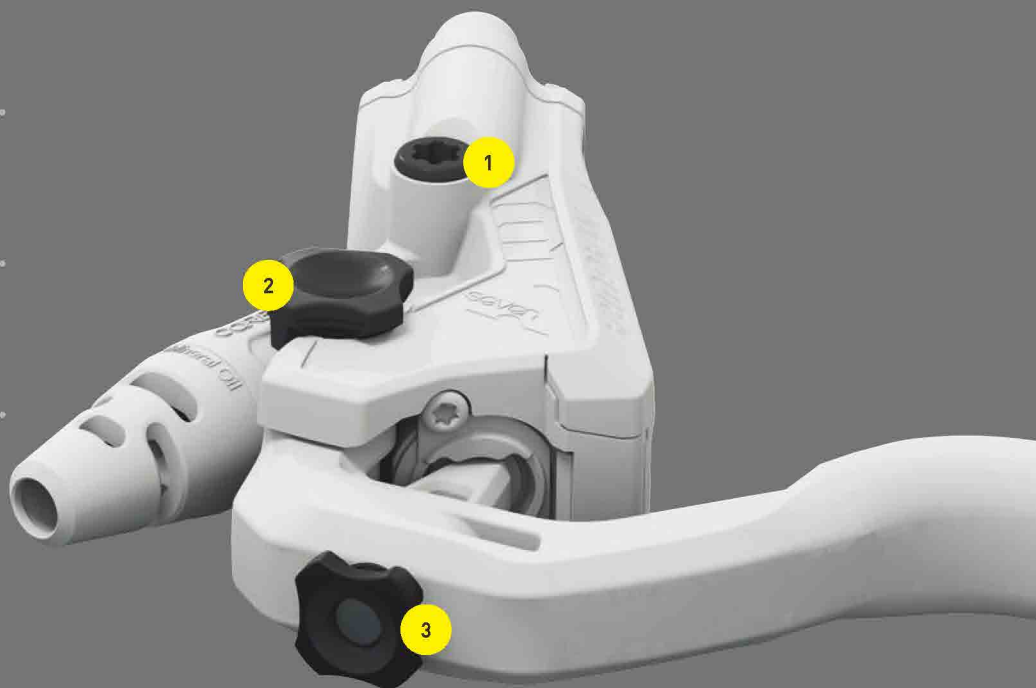

## 4 BANJO FITTING

### 可調式油管

Rotatable hose routing

可配合車架調整油管走線位置，最大調整角度為30度

## 5 MAGNETIXCHANGE

### 磁吸式來令片更換技術

Easy brake pad replacement

更換來令片輕鬆容易上手

## 6 TRIPLE ARCH DESIGN

### 三拱橋設計

Ultimate caliper rigidity

提供卡鉗絕佳剛性

 DESIGNED AND  
ENGINEERED IN GERMANY

 5 YEARS LEAK  
PROOF GUARANTEE

 FILLED WITH  
ROYAL BLOOD



# MT7 PRO

The clearly defined bite point and maximum power make it the first choice for gravity and high-speed pilots. The 1-finger HC lever blade modulates the enormous braking power as desired.

精準煞車作動及強大制動力道，MT7 PRO是你征服瞬間急轉彎及陡峭下坡的最佳利器，全新開發的單指HC拉柄，讓你隨心所欲操控完美制動力道。

Weight 重量	255 g
Master 煞車本體	Carbotecture SL® 高科技碳纖維複合材質
Lever blade 煞車拉柄	1-Finger HC, Hollow Aluminium 單指HC鋁製中空拉柄
Reach adjust 握距調整	toolless 免工具
Bite adjust 靈敏度調整	toolless 免工具
Pistons 活塞數	4
RRP 建議售價	219,90 €*
Order No. 產品編號	2 701 445



E-BIKE READY

AWARD-WINNING BRAKING PERFORMANCE

煞車性能屢獲殊榮

ADAPTABLE ERGONOMICS 符工人體工學

WEIGHT RATIO PERFORMANCE 最佳重量性能比



BEST IN TEST  
A PRODUCT GROUP TEST



MOUNTAINBIKE  
Leserwahl 2015  
Innovation des Jahres  
1. Platz



# MT5

Full gravity braking power of the 4 pistons as an affordable entry level. Our MT5 downhill and enduro model has all the genes of the MT7. Reliable and strong – also for e-bikes.

入門四活塞煞車最佳方式，擁有MT7 PRO的重口味特質，穩定且強大制動力道，同樣適用於電動自行車。

Weight 重量	255 g*
Master 煞車本體	Carbotecture® 獨家纖維複合材質
Lever blade 煞車拉柄	2-Finger, Aluminium 2指鋁合金拉柄
Reach adjust 握距調整	T25 tool T25星形螺絲起子
Bite adjust 靈敏度調整	-
Pistons 活塞數	4
RRP 建議售價	109,90 €*
Order No. 產品編號	2 700 477



E-BIKE READY

GENES OF THE MT7 內建MT7重力魂

ENTRY-LEVEL 4-PISTON BRAKING POWER

四活塞煞車最佳入門款

HIGH-QUALITY MATERIALS 高品質材料打造



BEST IN TEST  
A PRODUCT GROUP TEST

BEST VALUE  
A PRODUCT GROUP TEST



FREE-RIDE  
Bremsentest 02/2016  
Freeride-Ranglung:  
10/10 Punkte



\* without rotor/adapter 不含碟盤/轉接座

# DISC BRAKES

## MT TRAIL SL

MAGURA's definition of trail braking performance – 4 pistons in the front for maximum braking power, 2 pistons in the rear for perfect modulation. Thanks to the new 1-finger HC Carbon lever blade it just weigh around about 230 g (average value).

前所未有的「前四後二」搭配組合，MAGURA全新定義自行車！前輪四活塞提供絕佳制動力道；後輪雙活塞讓你擁有完美操控，搭配單指HC碳纖維拉柄，平均重量僅230g。

Weight 重量	240 g / 220 g
Master 煞車本體	Carbotecture SL® 高科技碳纖維複合材質
Lever blade 煞車拉柄	1-Finger HC, Carbon 單指HC碳纖維拉柄
Reach adjust 握距調整	3 mm allen key 3號內六角扳手
Bite adjust 靈敏度調整	-
Pistons 活塞數	4/2
RRP 建議售價	579,90 € (Set)*
Order No. 產品編號	2 701 646



MOUNTAINBIKE Testerteil

Sehr gut

## MT TRAIL SPORT

100 % trail performance at an attractive price. Almost as snappy and light as its big sister – and just as sensitive too. This is the new MAGURA entry into the 4/2 brake piston concept.

MT TRAIL SPORT提供100%林道越野煞車性能，煞車力道、輕量表現以及靈敏度近似姊妹款MT TRAIL SL，是進入MAGURA前四後二最佳入門方式。

Weight 重量	255 g / 230 g
Master 煞車本體	Carbotecture® 獨家纖維複合材質
Lever blade 煞車拉柄	1-Finger HC, Hollow Aluminium 單指鋁製中空拉柄
Reach adjust 握距調整	3 mm allen key 3號內六角扳手
Bite adjust 靈敏度調整	-
Pistons 活塞數	4/2
RRP 建議售價	219,90 € (Set)*
Order No. 產品編號	2 701 389



NEW



E-BIKE READY

100 % TRAIL PERFORMANCE  
發揮100%林道越野車煞車性能

LIGHTWEIGHT 輕量化

1-FINGER HC CARBON LEVER BLADE  
單指HC碳纖維拉柄



E-BIKE READY

GENES OF THE MT TRAIL SL  
內建MT TRAIL SL林道魂

1-FINGER HC LEVER BLADE 單指HC拉柄

ENTRY-LEVEL TRAIL BRAKING POWER  
林道越野最佳入門

\* without rotor/adapter 不含碟盤/轉接座







# DISC BRAKES

## MT8 SL

Perfect for cross country and marathon races: super light due to the Carbotecture SL® housing and with high braking power thanks to the new ergonomic 1-finger HC Carbon lever blade. All reasons professional races trust in this brake.

在XC及馬拉松最完美選擇！精準煞車力道和輕量化表現，歸功於煞車本體採用高科技碳纖維複合材質Carbotecture SL®，同時拉柄使用單指HC碳纖維拉柄，頂尖職業車手在賽場的最佳神隊友。

Weight 重量	195 g
Master 煞車本體	Carbotecture SL® 高科技碳纖維複合材質
Lever blade 煞車拉柄	1-Finger HC, Carbon 單指HC碳纖維拉柄
Reach adjust 握距調整	3 mm allen key 3號內六角扳手
Bite adjust 靈敏度調整	-
Pistons 活塞數	2
RRP 建議售價	279,90 €*
Order No. 產品編號	2 701 657



E-BIKE READY

ENGINEERED FOR RACING 為競賽而生

1-FINGER HC CARBON LEVER BLADE 單指HC碳纖維拉柄

LIGHTWEIGHT PERFORMANCE 高性能輕量化煞車



## MT8 PRO

The new MT8 Pro offers the same performance as the high-end MT8 SL model at an attractive price. Equipped with a 1-finger HC aluminium lever blade it provides reliability on tours and in competition.

新款MT8 Pro擁有與高端的MT8 SL相似表現性能，搭配單指HC鋁製中空拉柄與極具吸引力價格，提供你長程旅行騎乘及競賽絕佳可靠性。

Weight 重量	225 g
Master 煞車本體	Carbotecture SL® 高科技碳纖維複合材質
Lever blade 煞車拉柄	1-Finger HC, Hollow Aluminium 單指鋁製中空拉柄
Reach adjust 握距調整	toolless 免工具
Bite adjust 靈敏度調整	-
Pistons 活塞數	2
RRP 建議售價	179,90 €*
Order No. 產品編號	2 701 728



E-BIKE READY

GENES OF THE MT8 SL 內建MT8 SL競賽靈魂

ELEGANT CHROME POLISHED FINISH 優雅的鍍鉻拋光表面處理

LIGHTWEIGHT TECHNOLOGY 輕量化科技



## MT4

The perfect all-rounder for mountain bikers who value stability and braking power, without having to compromise on weight. The Carbotecture® master keeps the entire weight to 230 grams.

走全能路線的MT4，擁有穩定可造的煞車力道，以及絕不妥協的輕量化特性，獨家纖維複合材質Carbotecture®打造，讓整體重量僅有230g。

Weight 重量	230 g
Master 煞車本體	Carbotecture® 獨家纖維複合材質
Lever blade 煞車拉柄	2-Finger, Aluminium 2指鋁合金拉柄
Reach adjust 握距調整	T25 tool T25星形螺絲起子
Bite adjust 靈敏度調整	-
Pistons 活塞數	2
RRP 建議售價	89,90 €*
Order No. 產品編號	2 700 476



E-BIKE READY

PERFECT ALL-ROUNDER 完美演繹全能風采

VERY GOOD PRICE/PERFORMANCE RATIO 最佳性能與價格

INNOVATIVE TECHNOLOGY 創新科技

## MT SPORT

The entry level to the MAGURA MT world. With all of the high-tech features of german engineering skill, such as lightweight Carbotecture® components and the improved MAGURA discube for safe stopping on tour and in the city.

進入MAGURA MT系列煞車最佳管道，設計概念處處可見德式工藝精神，採用輕量化的獨家纖維複合材質Carbotecture®，並在油管加以進化，無論是旅行或是城市中漫遊，提供你在騎乘更精確、安全的煞車。

Weight 重量	245 g
Master 煞車本體	Carbotecture® 獨家纖維複合材質
Lever blade 煞車拉柄	2-Finger, Carbotecture® 2指獨家纖維複合材質拉柄
Reach adjust 握距調整	T25 tool T25星形螺絲起子
Bite adjust 靈敏度調整	-
Pistons 活塞數	2
RRP 建議售價	59,90 €*
Order No. 產品編號	2 701 705



E-BIKE READY

JOIN THE MAGURA MT FAMILY 最佳進入MAGURA碟煞家族

FULL CARBOTECTURE® MASTER 煞車本體採獨家材料打造

VERY GOOD PRICE/WEIGHT RATIO 絕佳價格與重量比

\*without rotor/adapter 不含碟盤/轉接座

# DISC BRAKES FLATMOUNT TECHNOLOGY 碟煞平裝式卡鉗科技



1 **MAGNETIXCHANGE**  
磁吸式來令片更換技術  
Easy brake pad replacement  
更換來令片輕鬆容易上手

2 **FLATMOUNT MOUNTING**  
平裝式安裝  
Caliper with threads [M5], easy mounting  
卡鉗使用M5螺紋，容易安裝

3 **STANDARD 2 PISTONS MT BRAKE PADS**  
標準二活塞來令片  
High braking performance and stability  
擁有強大煞車性能及穩定性

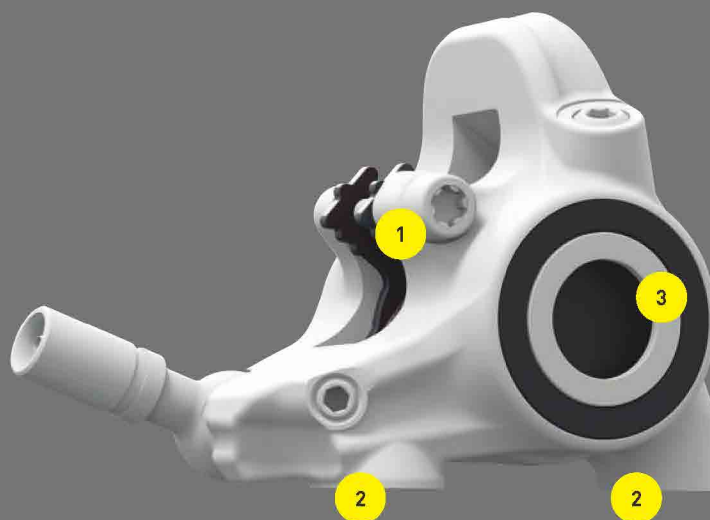

## Flatmount brakes

The flatmount brake is characterized by integrated threads in the caliper, which are fastened with M5 screws. The compact design and integrated threads simplify the mounting on the chain stay. Due to the same brake pad and pistons size of the standard 2 pistons MT brake, the flatmount brake is just as strong as the postmount variant.

## 平裝式卡鉗

平裝式卡鉗採用M5螺絲即能固定，緊湊扁平一體式設計減少使用空間，同時MAGURA在卡鉗上保留活塞及來令片標準尺寸，車友們可使用MAGURA原有來令片，讓平裝式卡鉗與柱式安裝（Post mount）發揮同樣強大功能表現。

 **DESIGNED AND  
ENGINEERED IN GERMANY**

**5** YEARS LEAK  
PROOF GUARANTEE

 **FILLED WITH  
ROYAL BLOOD**



## MT8 SL FLATMOUNT

With the MT8 SL FM, ambitious cross-country racers can brake right when they want to – at the last moment. The MT8 SL FM accommodates brake discs up to 160 mm, making it just as powerful and wear-resistant as the MT8 SL, on which it is based.

憑藉MT8 SL FM，雄心勃勃的越XC車手們，可以在他們最後一刻想煞車時，獲得精準無誤的制動表現。MT8 SL FM最大可容納160 mm的碟盤，性能表現與其與MT8 SL一樣強大和耐磨。

Weight 重量	185 g
Master 煞車本體	Carbotecture SL® 高科技碳纖維複合材質
Lever blade 煞車拉柄	1-Finger HC, Carbon 單指HC碳纖維拉柄
Reach adjust 握距調整	3 mm allen key 3號內六角扳手
Bite adjust 靈敏度調整	-
Pistons 活塞數	2
RRP 建議售價	279,90 €*
Order No. 產品編號	2 701 632



E-BIKE READY

LOW-WEAR 低磨損

INTEGRATED DESIGN 一體成型設計

SUITABLE FOR RACING 適合競賽使用

## MT4 FLATMOUNT

Elegant and slim, but with a powerful bite. Although it has a more compact design, the MT4 FM takes our standard brake pads, so it is just as resistant to heat and dirt as our “large” models.

外觀優雅但制動表現強勁，雖然卡鉗為較Post Mount體積小，但MT4 FM採用標準來令片，整體性能與「大型」煞車同樣有耐熱和防塵特點。

Weight 重量	220 g
Master 煞車本體	Carbotecture® 獨家纖維複合材質
Lever blade 煞車拉柄	2-Finger, Aluminium 2指鋁合金拉柄
Reach adjust 握距調整	T25 tool T25星形螺絲起子
Bite adjust 靈敏度調整	-
Pistons 活塞數	2
RRP 建議售價	129,90 €*
Order No. 產品編號	2 701 633



E-BIKE READY

COMPACT DESIGN 緊湊設計

TORSION-RESISTANT 抗扭轉能力佳

STANDARD BRAKE PADS 可使用標準來令片

\* without rotor/adapter 不含碟盤/轉接座







**RIM / BRAKES**

# RIM BRAKES

## 輪圈煞車系列

### HS TECHNOLOGY

#### 經典HS獨家技術



#### 1 BRAKE BOOSTER

##### 煞車補強片

Brake booster for optimised bite point  
避免煞車力道大於車架受力而產生變型

#### 2 EASY PAD REPLACEMENT

##### 煞車塊換設計

Easy brake pad replacement  
大幅簡化煞車塊更換作業

#### 3 HS EASY MOUNT

##### 簡易安裝HS煞車

Easy mounting and adjustment  
提供更簡易的安裝及調整步驟

#### 4 EV02

##### 固定座

Flexible adaptation to all systems  
更彈性適應所有系統

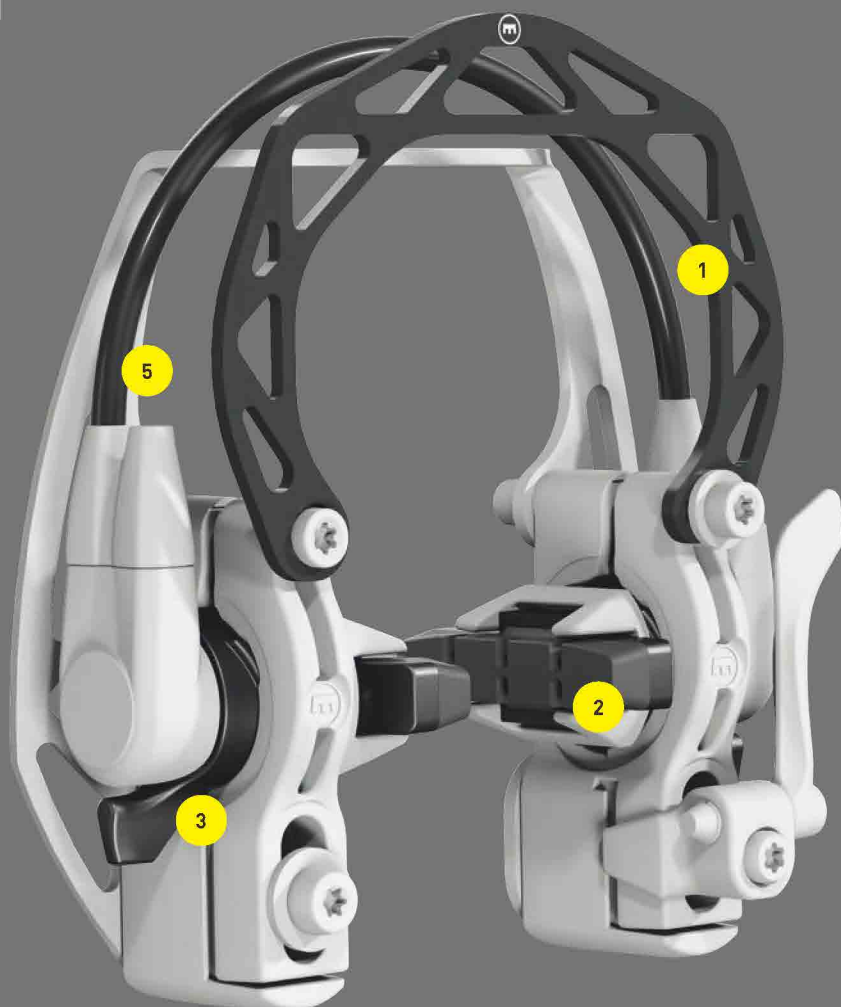

#### 5 MORE BRAKING POWER FOR E-BIKES

##### 提供電動自行車更強大制動

Thanks to optimized brake hose  
得益於優化的煞車油管

#### 6 EASY BLEED

##### 易注油技術

Quick and easy bleeding  
灌油作業超簡單

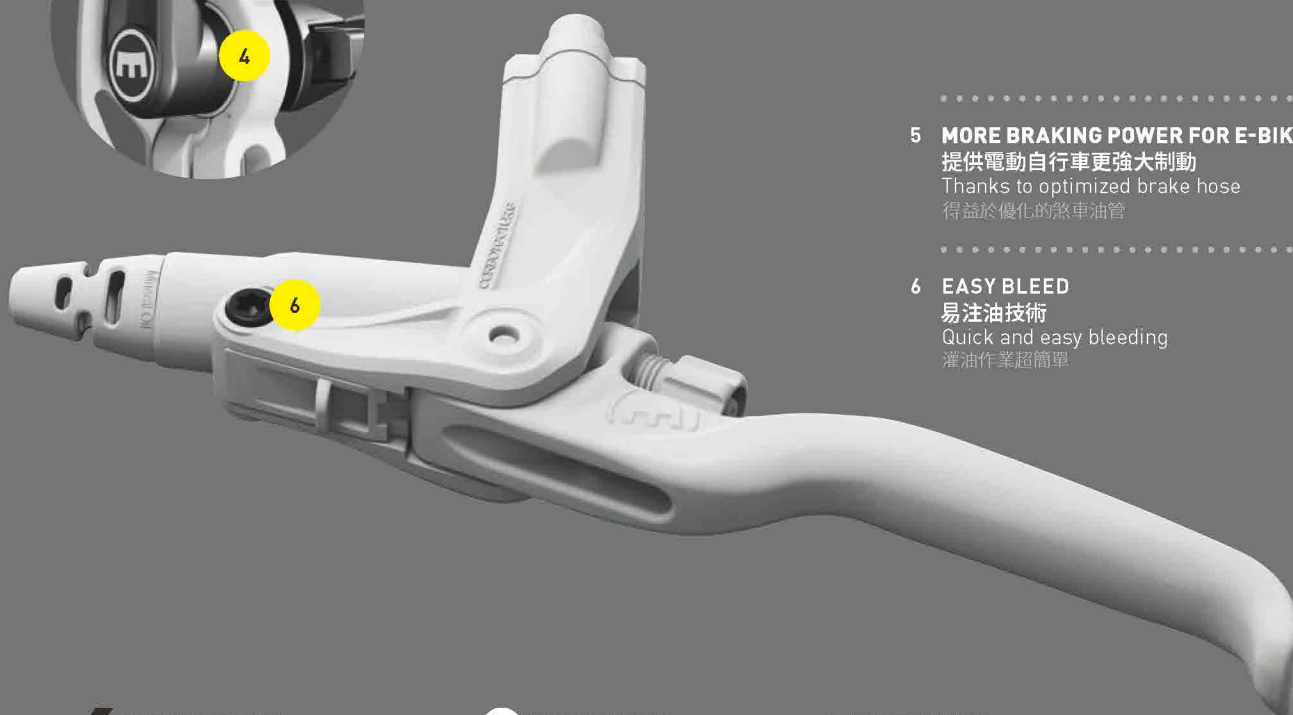

 **DESIGNED AND  
ENGINEERED IN GERMANY**

**5 YEARS LEAK  
PROOF GUARANTEE**

 **FILLED WITH  
ROYAL BLOOD**



# HS33

Our unbeatable classic. The MAGURA top model of the carefree family scores with sheer reliability and offers increased braking power and low weight.

為MAGURA高階輪圈煞車經典不敗款，HS33的可靠穩定的性能，在全球自行車愛好者擁有崇高地位，輕量化及高制動力特點，更讓車友們一試即成老主顧。

Weight 重量	480 g
Master 煞車本體	Carbotecture® 獨家纖維複合材質
Lever blade 煞車拉柄	2-Finger, Aluminium opt.: 4-Finger, Aluminium 2指鋁合金拉柄 可選配4指鋁合金拉柄
Reach adjust 握距調整	T25 tool T25星形螺絲起子
Pad wear adjustment 煞車塊間隙調整	TPA 調整鈕
Mounting 煞車固定座	Cantilever EVO2
RRP 建議售價	109,90 €
Order No. 產品編號	2 700 246 <sup>a</sup>

More colors: 2 700 246: black, 2-Finger / 2 700 245: silver, 2-Finger / 2 700 247: black, 4-Finger  
更多選項:  
2 700 246 黑色兩指拉柄 ; 2 700 245 銀色兩指拉柄 ;  
2 700 247 黑色四指拉柄



E-BIKE READY

SPORTY DESIGN 運動風設計

THE FLAGSHIP OF CAREFREE BRAKES 輪圈煞車旗艦款

HUGE BRAKING POWER FOR RIM BRAKES 擁有最強勁煞車力道



Photo: Philip Ruopp

# RIM BRAKES

## HS22

Fitted to many award-winning bicycles, because commuter and trekking riders value safety and maintenance-free features. The Royal Blood can remain in the brake hose forever.

穩定可靠且幾乎不需保養的特點，深獲單車通勤及喜愛單車旅行車友青睞，以皇家血統礦物油為傳動媒介，HS22現今在多款獲獎的車款上可見其身影。

Weight 重量	480 g
Master 煞車本體	Carbotecture® 獨家纖維複合材質
Lever blade 煞車拉柄	3-Finger, Carbotecture® 3指獨家纖維複合材質拉柄
Reach adjust 握距調整	toolless 免工具
Pad wear adjustment 煞車塊間隙調整	TPA 調整鈕
Mounting 煞車固定座	Cantilever EVO2, Easy Mount EVO2固定座
RRP 建議售價	89,90 €
Order No. 產品編號	2 700 845 <sup>b</sup>



E-BIKE READY

**PROVEN ERGONOMICS**  
經驗證的人體工學設計

**ELEGANT DESIGN AND HIGH-QUALITY MATERIALS** 典雅設計與高質

**TOOLLESS BRAKE PAD ADJUSTMENT** 免工具煞車塊調整

## HS11

The youngest in the family is just as reliable as its sisters, scoring with high braking power in everyday cycling. It's also comfortable, thanks to the ergonomic lever blade design.

在HS輪圈煞車家族最年輕的HS11，不讓其姊妹專美於前，憑著可靠性能表現嶄露頭角，符合人體工學拉柄設計，提供更舒適手感。

Weight 重量	435 g
Master 煞車本體	Carbotecture® 獨家纖維複合材質
Lever blade 煞車拉柄	3-Finger, Carbotecture® 3指獨家纖維複合材質拉柄
Reach adjust 握距調整	-
Pad wear adjustment 煞車塊間隙調整	T25 tool T25 星形螺絲起子
Mounting 煞車固定座	Cantilever EVO2, Easy Mount EVO2固定座
RRP 建議售價	69,90 €
Order No. 產品編號	2 701 214 <sup>c</sup>



E-BIKE READY

**THE CAREFREE BRAKE**  
無須費心照顧的煞車系統

**ERGONOMIC AND STRONG** 符合人體工學堅固耐用

**PRECISE CONTROL** 提供精準操控性

<sup>b</sup> 2 700 845: 3-fingers, EVO2 / 2 700 846: 3-fingers, Easy Mount 2 700 845: 3-fingers, EVO2 / 3指拉柄、EVO2固定座；2 700 846: 3-fingers, Easy Mount / 3指拉柄、簡易安裝固定座  
<sup>c</sup> 2 701 214: 3-fingers, EVO2 / 2 701 252: 3-fingers, Easy Mount 2 701 214: 3-fingers, EVO2 / 3指拉柄、EVO2固定座；2 701 252: 3-fingers, Easy Mount / 3指拉柄、簡易安裝固定座



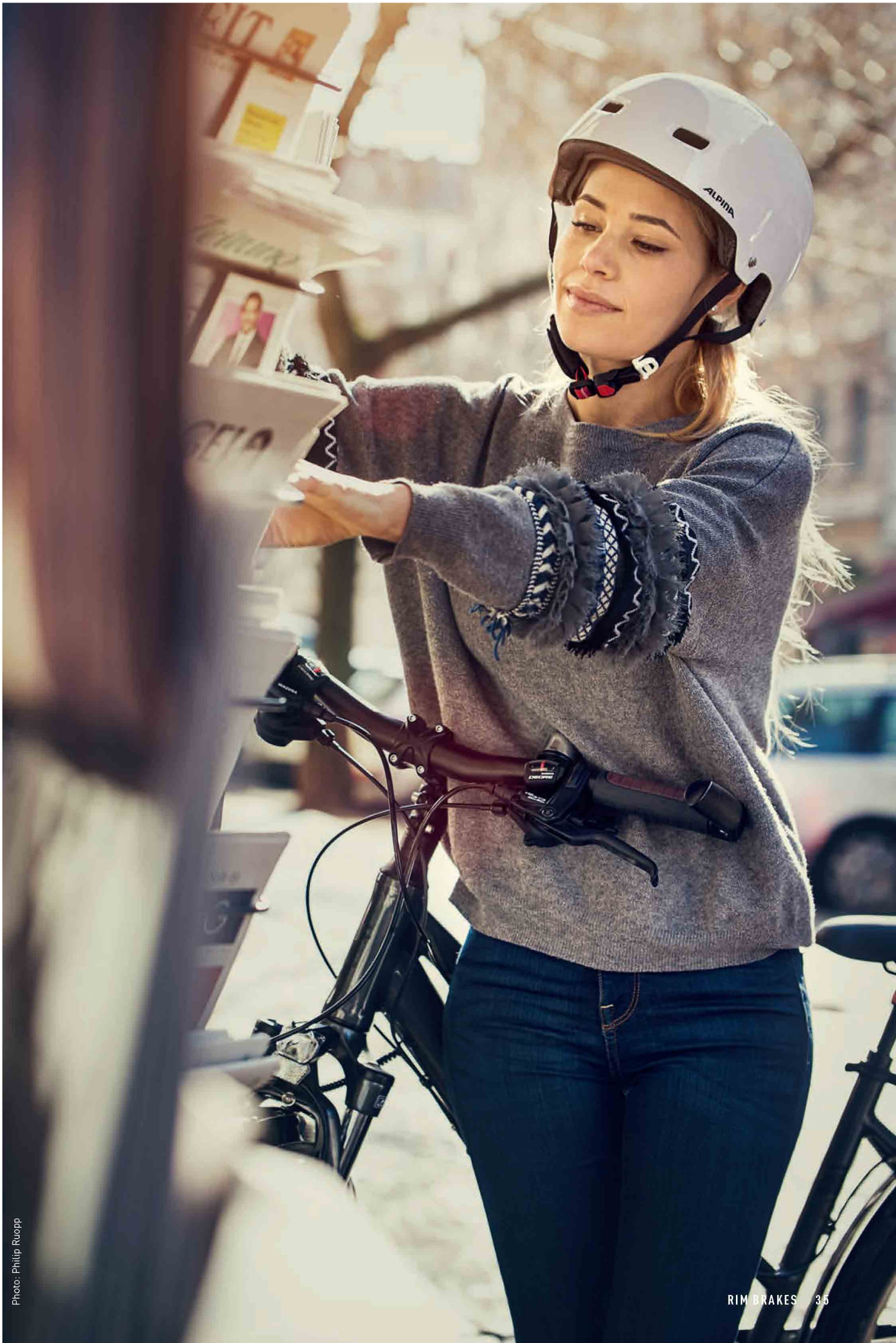







# S-PEDELEC BRAKES

# S-PEDELEC BRAKES TECHNOLOGY

## 高速電動自行車煞車科技



### 1 BRAKE POWER

#### 煞車制動力

4 pistons for maximum braking power and stability

四活塞卡鉗提供最強大的制動力及穩定性

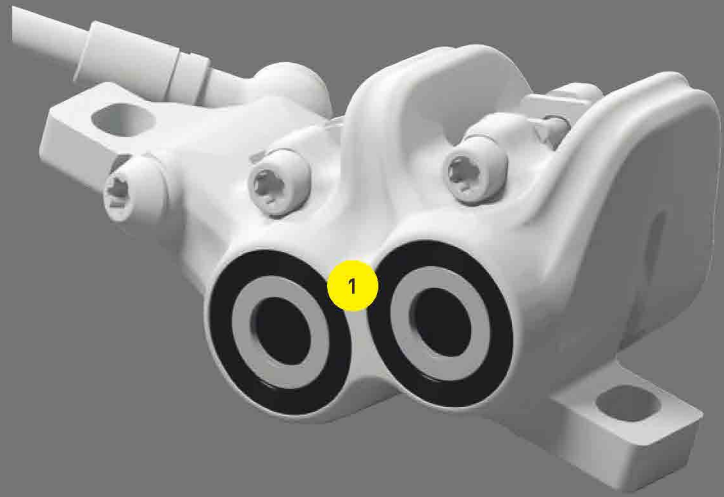

### 2 S-PEDELEC SWITCH

#### 高速電動自行車斷電開關

Activates brake light and controls the motor cut-off

可控制煞車燈及截斷電控馬達

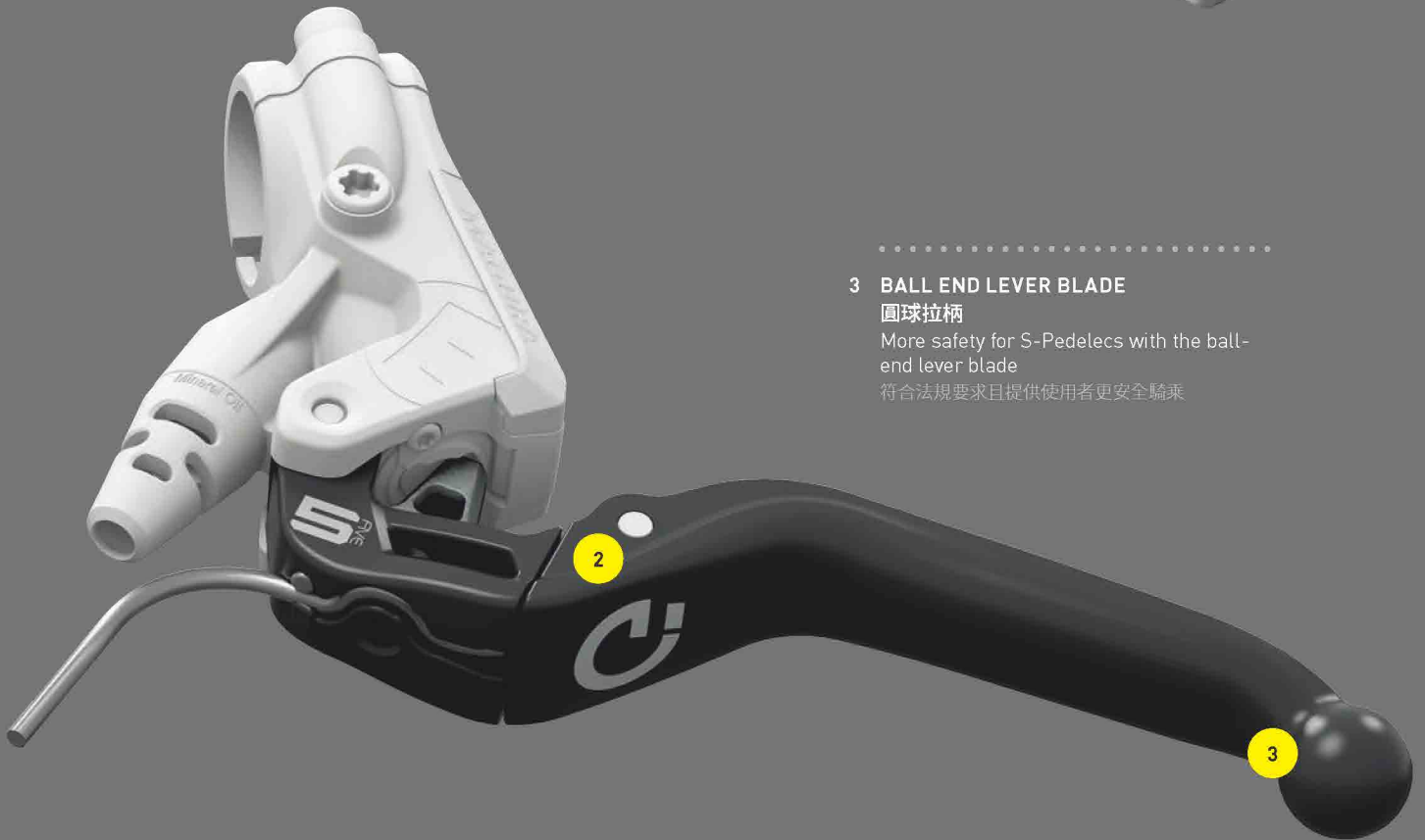

### 3 BALL END LEVER BLADE

#### 圓球拉柄

More safety for S-Pedelecs with the ball-end lever blade

符合法規要求且提供使用者更安全騎乘

 DESIGNED AND  
ENGINEERED IN GERMANY

 5 YEARS LEAK  
PROOF GUARANTEE

 FILLED WITH  
ROYAL BLOOD



# MT5e

Brakes everything including the motor (cut off) - experiences from the motorcycle sector coupled with know-how for s-pedelecs. The braking force of the 4 pistons and outstanding stability make s-pedelecs much safer.

MAGURA於摩托車領域的經驗及專業知識，應用在高速電動車更顯遊刃有餘。四活塞制動力及高穩定性，提供高速電動自行車更高的安全性。

Weight 重量	275 g
Master 煞車本體	Carbotecture® 獨家纖維複合材質
Lever blade 煞車拉柄	3-finger ball-end, aluminium with switch 3指鋁合金圓球拉柄 並搭配斷電開關
Reach adjust 握距調整	3 mm allen key 3號內六角扳手
Bite adjust 靈敏度調整	-
Pistons 活塞數	4
RRP 建議售價	139,90 €*
Order No. 產品編號	2 700 984 †



Photo: Philip Ruopp

\* without rotor/adapter 不含碟盤/轉接座

† 2 700 984: HIGO-Closer HIGO常閉式 / 2 700 985: HIGO-Opener HIGO常閉式

# S-PEDELEC BRAKES

## MT4e

Here, safety is spelled 4e: even before braking starts, a switch of the MT4e activates the brake light and/or cuts off the motor (cut off). Our all-round disc brake with all the features for s-pedelecs.

安全的代名詞 - MT4e! 在煞車作動前, MT4e就已準備好啟動煞車燈或截斷電控馬達, 完全演繹高速電動自行車煞車的全能特性。

Weight 重量	250 g
Master 煞車本體	Carbotecture® 獨家纖維複合材質
Lever blade 煞車拉柄	3-finger ball-end, aluminium with switch 3指鋁合金圓球拉柄並搭配斷電開關
Reach adjust 握距調整	3 mm allen key 3號內六角扳手
Bite adjust 靈敏度調整	-
Pistons 活塞數	2

\* Not available in the aftermarket. 補修市場暫無發售



## HS33e

The HS33 Re is a hydraulic rim brake specially designed for s-pedelec. With high braking power and perfect ergonomics, it's the ideal partner for town and country.

HS33e是專為高速電動自行車設計的液壓輪圈煞, 具備更強的煞車力道與更完臻的人體工學設計, 是通勤最佳理想選擇。

Weight 重量	500 g
Master 煞車本體	Carbotecture® 獨家纖維複合材質
Lever blade 煞車拉柄	3-finger ball-end, aluminium with switch 3指鋁合金圓球拉柄並搭配斷電開關
Reach adjust 握距調整	T25 tool T25星形螺絲起子
Pad wear adjustment 煞車塊間隙調整	TPA 調整鈕
Mounting 煞車固定座	Cantilever EVO2

Not available in the aftermarket. 補修市場暫無發售









6 Nm



A close-up, dark-toned photograph of a car seat's interior. The seat is upholstered in a dark, textured fabric. A black dropper seatpost is visible, extending from the seat. A bright yellow diagonal line runs across the image, intersecting the text. The background shows a blurred view of a mountainous landscape.

# **DROPPER SEATPOST**

# DROPPER SEATPOST

## VYRON eLECT TECHNOLOGY

### 無線伸縮座桿

### VYRON eLECT 智慧連接技術

#### 1 VARIABLE POSITIONING

##### 無段式調整

Variable positioning of the saddle height possible

使用者可輕鬆調整到任何想要的高度

#### 2 SPEED

##### 迅速反應

Fast reaction and extension speed

快速感應且立即調整座管高度

#### 3 PLUG 'N' PLAY

##### 即插即用

Easily mounted without cables

沒有走線束縛且能快速安裝

#### 4 EXCHANGEABLE ELECTRONIC UNIT

##### 可替式電子組件

Electronic unit can be exchanged separately during service support

保固期間內，電子組件可單獨更換

#### 5 REMOTE

##### 無線控制

Control of the seatpost via the remote on the handlebar

遙控器安裝於車把手，並可用來調整座管高低



#### No cables – no problems.

The innovative eLECT technology by MAGURA controls the dropper seatpost VYRON electronically and wirelessly via the remote. No time-consuming wiring problems – MAGURA gives you control at the push of a button. MAGURA suspension forks and rear shocks from the year 2010 can also be converted to the eLECT technology with the eLECT upgrade kit – then the remote can control all the products.

#### 無線不受限

由MAGURA創新開發的無線伸縮座管，運用電子及無線科技，使用者只要輕鬆按下遙控器的按鈕，就能輕鬆使用控制，方便省時且迅速。MAGURA在2010年後推出的避震前叉及阻尼，可透過eLECT智慧套件進行升級，同樣只需一個遙控器，就可以控制所有產品。



# VYRON eLECT SEATPOST

No cables, no laborious cable routing. The VYRON eLECT seatpost with wireless remote control is a technical trail-blazer. The hydraulic system can be infinitely adjusted to the desired height by pushing the remote.

沒有走線束縛、更不須費心保養，VYRON eLECT無線遙控伸縮座桿是技術的開拓者，透過遙控器即可輕鬆簡單把座管高度，調整到你想要的位置。

Weight 重量	595 g
Material 材料	black-anodized 黑色陽極
Lenght 長度	396/421/446 mm (depending on model) (依型號不同)
Travel 行程	100 mm / 125 mm / 150 mm variable positioning (depending on model) 無段式調整(依型號不同)
Charging connector 充電連接	Micro-USB
Charging time 充電時間	approx. 3 h 約3小時
Charge after 充電後	approx. 400 activations 約可使用400次
Remote 遙控器	Wireless Remote Control inkl. Remote Cap 無線遙控包括遙控蓋
RRP 建議售價	449,90 €
Order -No. 產品編號	Ø 30,9 mm: 2 701 423 / 150 mm 2 701 424 / 125 mm 2 701 425 / 100 mm Ø 31,6 mm: 2 701 426 / 150 mm 2 701 427 / 125 mm 2 701 428 / 100 mm



**WIRELESS 無線科技**  
**VARIABLE POSITIONING**  
**無段式調整**  
**PLUG' N' PLAY 隨插即用**



**MOUNTAINBIKE**  
Leserwahl 2016  
Innovation des Jahres  
3. Platz



## REMOTE CAP 遙控蓋

RRP 建議售價 9,90 €  
Order-No. 2 701 282  
產品編號

The Remote Cap makes using the VYRON child's play. Safety at the push of a button, even in tricky situations: the large contact area between the thumb and the remote makes every thumb pressure count.

輕巧的遙控蓋，讓控制VYRON更加輕而易舉。遙控蓋讓遙控的按鈕接觸面變大，無論任何棘手環境都能輕易按下按鈕，即使戴手套也能輕鬆控制。

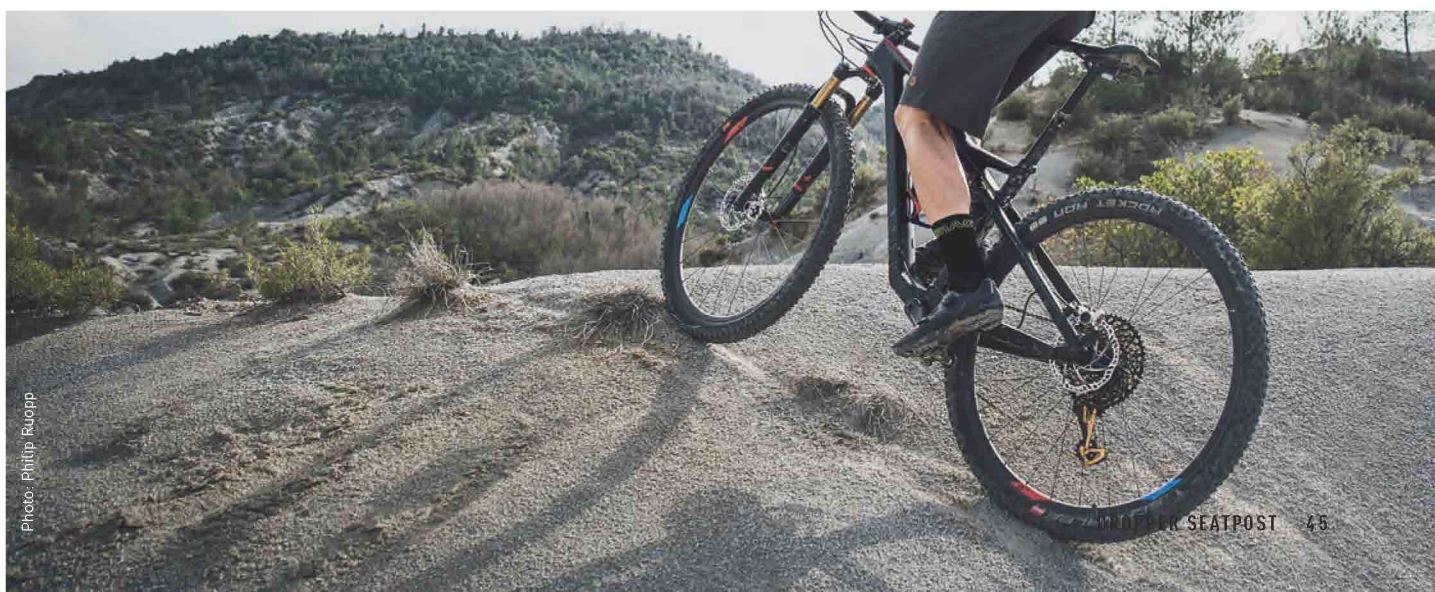





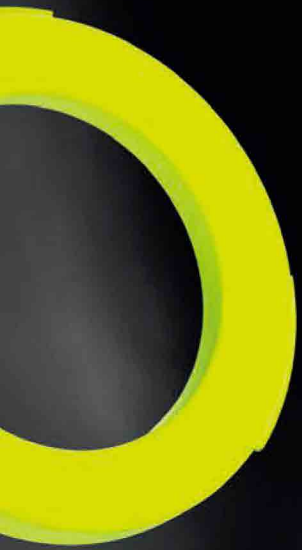

# TUNING PARTS

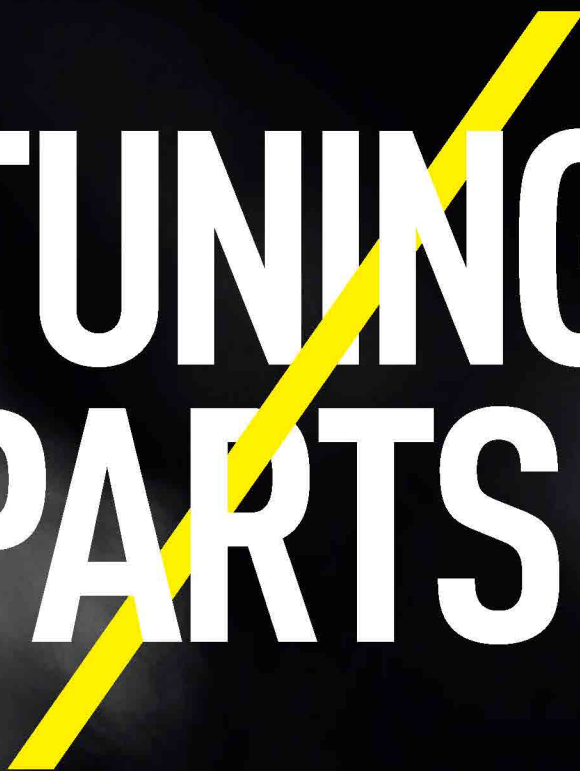

# TUNING PARTS 獨家絕配

## CUSTOMIZE YOUR BIKE

### 你的個性化煞車

#### Individuality is the key.

It's easy to make your bike unique with MAGURA Tuning Parts. The covers on the calipers are replaced with just one click – and there are now 12 colours to choose from. Matching handlebar clamps complete the unmistakable look. However, optical tuning is not everything. Thanks to an upgrade with a new lever blade, e.g. the 1-finger HC3 lever blade, you can adjust your brake individually to optimise your performance. The HC3 lever blade offers you lever reach adjust and a ratio adjust that allows you to tune brake power and modulation.

#### 個性是關鍵

使用MAGURA 獨家配件，帥氣展現個性化煞車！「貓頭鷹眼睛」的卡鉗環共有12種顏色選擇；煞把固定環與你一起大膽玩色，迅速吸引眾人目光。然而顏色並非是個性化目的，單指拉柄HC3採用鋁合金打造，具有「調整握距」及「煞把槓桿比率」的功能，讓每位騎乘者都可完美找到自身最愛的煞車手感。





# LEVER BLADES

## 我選我煞：拉柄

For Carbotecture SL [MT6/MT8/MT7/MT TRAIL CARBON/SL from MY 2015]  
煞車本體為Carbotecture SL®(適用於MY2015年後的MT6/MT8/MT7/MT TRAIL CARBON/SL)



HC3 LEVER BLADE HC3拉柄	Order Number 產品編號	RRP 建議售價
1-finger aluminium, Ratio Adjust with tool (PU = 1 piece) 單指鋁合金拉柄，使用工具可調整握距，以及煞把橫桿比	2 701 251	67,90 €



HC CARBON LEVER BLADE HC碳纖維拉柄	Order Number 產品編號	RRP 建議售價
1-finger Carbon, Reach Adjust with tool (PU = 1 piece) 單指碳纖維拉柄，使用工具可調整握距	2 701 631	89,90 €



HC LEVER BLADE HC拉柄	Order Number 產品編號	RRP 建議售價
1-finger aluminium, Reach Adjust with tool (PU = 1 piece) 單指鋁合金拉柄，使用工具可調整握距	2 701 247	35,90 €

1-finger aluminium, with Reach Adjust, black (PU = 1 piece) 單指鋁合金拉柄，免工具握距調整旋鈕（黑色）	2 701 246	37,90 €
--	-----------	---------

1-finger aluminium, with Reach Adjust, chrome (PU = 1 piece) 單指鋁合金拉柄，免工具握距調整旋鈕（銀色）	2 701 248	37,90 €
---	-----------	---------



2-FINGER LEVER BLADE 兩指拉柄	Order Number 產品編號	RRP 建議售價
2-finger aluminium, with Reach Adjust (PU = 1 piece) 兩指鋁合金拉柄，使用工具可調整握距	2 701 215	37,90 €

For Carbotecture [MT4/MT5/MT TRAIL SPORT from MY 2015]  
煞車本體為Carbotecture（適用於MY2015年後的(MT4/MT5/MT TRAIL SPORT)



HC LEVER BLADE HC拉柄	Order Number 產品編號	RRP 建議售價
1-finger aluminium, Reach Adjust with tool, for MT TRAIL SPORT, from MY2017 (PU = 1 piece) 單指鋁合金拉柄，使用工具可調整握距，適用於MY2017年後的MT TRAIL SPORT	2 701 369	34,90 €

1-finger aluminium, Reach Adjust with tool, for MT5, from MY2015 (PU = 1 piece) 單指鋁合金拉柄，使用工具可調整握距，適用於MY2015年後的MT5	2 701 249	34,90 €
--	-----------	---------

1-finger aluminium, Reach Adjust with tool, for MT4 (PU = 1 piece) 單指鋁合金拉柄，使用工具可調整握距，適用於MT4	2 701 250	34,90 €
--	-----------	---------



2-FINGER LEVER BLADE 兩指拉柄	Order Number 產品編號	RRP 建議售價
2-finger aluminium light-weight lever blade, Reach Adjust with tool, for MT5 or MT TRAIL SPORT, from MY2015 (PU = 1 piece) 兩指輕量化鋁合金拉柄，使用工具可調整握距，適用於MY2015年的MT4、MT5或MT TRAIL SPORT	2 700 538	25,90 €

# TUNING PARTS

## COVER-KITS

### 我選我煞：卡鉗環



#### COVER-KIT, 2 PISTONS 二活塞卡鉗環

Cover-Kit for caliper, from MY 2015 (blue, neon red, neon yellow), (PU = 6 pieces)  
適用於MY 2015年後的二活塞卡鉗 (經典藍、霓虹紅、霓虹黃)

Order Number  
產品編號

2 701 239

RRP  
建議售價

9,90 €

Cover-Kit for caliper, from MY 2015 (purple, red, neon pink), (PU = 6 pieces)  
適用於MY 2015年後的二活塞卡鉗 (魔幻紫、熱情紅、霓虹粉)

2 701 722

9,90 €

Cover-Kit for caliper, from MY 2015 (white, gold, silver), (PU = 6 pieces)  
適用於MY 2015年後的二活塞卡鉗 (純潔白、尊貴金、鑽石銀)

2 701 723

9,90 €

Cover-Kit for caliper, from MY 2015 (neon green, cyan, mint green), (PU = 6 pieces)  
適用於MY 2015年後的二活塞卡鉗 (霓虹綠、淡雅青、薄荷綠)

2 701 724

9,90 €

#### COVER-KIT, 4 PISTONS 四活塞卡鉗環

Cover-Kit for caliper, from MY 2015 (blue, neon red, neon yellow), (PU = 12 pieces)  
適用於MY 2015年後的四活塞卡鉗 (經典藍、霓虹紅、霓虹黃)

Order Number  
產品編號

2 701 240

RRP  
建議售價

13,90 €

Cover-Kit for caliper, from MY 2015 (purple, red, neon pink), (PU = 12 pieces)  
適用於MY 2015年後的四活塞卡鉗 (魔幻紫、熱情紅、霓虹粉)

2701719

13,90 €

Cover-Kit for caliper, from MY 2015 (white, gold, silver), (PU = 12 pieces)  
適用於MY 2015年後的四活塞卡鉗 (純潔白、尊貴金、鑽石銀)

2701720

13,90 €

Cover-Kit for caliper, from MY 2015 (neon green, cyan, mint green), (PU = 12 pieces)  
適用於MY 2015年後的四活塞卡鉗 (霓虹綠、淡雅青、薄荷綠)

2701721

13,90 €

**YOUR BIKE  
— YOUR STYLE**



# HANDLEBAR CLAMPS

## 我選我煞：煞把固定環



### SHIFTMIX HANDLEBAR CLAMP 整合式煞把固定環

	Order Number 產品編號	RRP 建議售價
Shiftmix 1+2, for Shimano I-Spec I+II left and right (pair) [PU = 1 piece left, 1 piece right] 可與Shimano I-Spec I+II整合，左右邊（一對）（一包裝：左右邊各一個）	2 701 241	39,90 €
Shiftmix 1+2, for Shimano I-Spec I+II left [PU = 1 piece] 可與Shimano I-Spec I+II整合，左邊	2 701 242	20,90 €
Shiftmix 1+2, for Shimano I-Spec I+II right [PU = 1 piece] 可與SRAM Trigger整合，左邊	2 701 243	20,90 €
Shiftmix 3, for SRAM Trigger left and right (pair) [PU = 1 piece left, 1 piece right] 可與SRAM Trigger整合，左右邊（一對）（一包裝：左右邊各一個）	0 724 710	39,90 €
Shiftmix 3, for SRAM Trigger left [PU = 1 piece] 可與SRAM Trigger整合，左邊	2 700 840	20,90 €
Shiftmix 3, for SRAM Trigger right [PU = 1 piece] 可與SRAM Trigger整合，右邊	2 700 841	20,90 €



### HANDLEBAR CLAMP 煞把固定環

	Order Number 產品編號	RRP 建議售價
Carbon, no screws [PU = 1 piece] Carbon製，不含螺絲	0 724 709	20,90 €
Aluminium, neon yellow, no screws [PU = 1 piece] 鋁合金製，霓虹黃，不含螺絲	2 700 751	11,90 €
Aluminium, neon red, no screws [PU = 1 piece] 鋁合金製，霓虹紅，不含螺絲	2 700 752	11,90 €
Aluminium, neon blue, no screws [PU = 1 piece] 鋁合金製，霓虹藍，不含螺絲	2 700 753	11,90 €
Aluminium, chrome polished, no screws [PU = 1 piece] 鋁合金製，鍍鉻銀，不含螺絲	2 701 244	9,90 €
Aluminium, black, no screws [PU = 1 piece] 鋁合金製，黑色，不含螺絲	0 724 488	9,90 €
Aluminium, silver, no screws [PU = 1 piece] 鋁合金製，亮銀色，不含螺絲	0 724 489	9,90 €
Carbotecture®, black, no screws [PU = 1 piece] 獨家複合材質Carbotecture®，黑色，不含螺絲	2 700 136	7,90 €
Carbotecture® silver, no screws [PU = 1 piece] 獨家複合材質Carbotecture®，銀色，不含螺絲	2 700 137	7,90 €







**ORIGINAL  
SPARE PARTS**

ORIGINAL SPARE PARTS

BEST PARTS = BEST PERFORMANCE

最佳支持：高品質原廠補修件

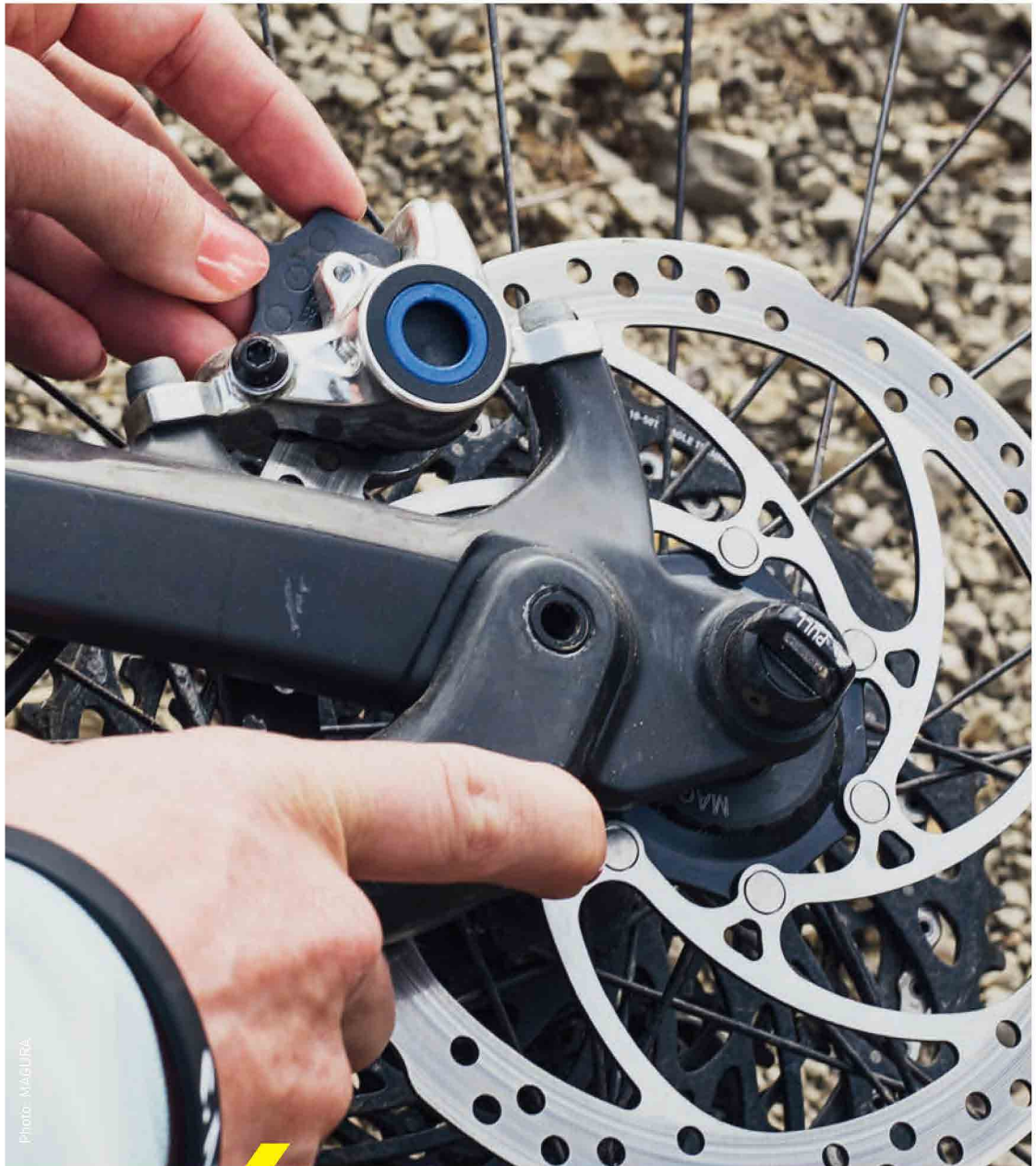

**SAFETY  
MATTERS**





# BRAKE PADS OVERVIEW

## 煞車塊與來令片總覽

### DISC BRAKE PADS 碟煞來令片

#### PERFORMANCE 功效型

For long tours these pads offer safety together with excellent performance in all situations. 功效型來令片，適用於長途旅行騎乘，在任何路況都能提供穩定、安全的制動表現。



Only available for brake pad 7., 8. and 9. 僅適用於來令片7.、8.與9.系列。

#### COMFORT 舒適型

For riders who want control rather than bite from their brakes as well as those looking for a long-lasting product.



舒適型來令片，提供平穩煞車操控，適合尋求溫和制動力的車，來令片的使用壽命相對較長。



Only available for brake pad 7. and 9. 僅適用於來令片7.與9.系列。

#### RACE 競賽型

For all those who bring their material to the limits during cross country or downhill and require outstanding braking performance.

競賽型來令片，提供最大制動力道，適用下坡車或較激烈的越野路況。



\* slight deviation in the case of 8.R 在8.R會略有偏差

Only available for brake pad 7. and 8. 僅適用於來令片7.與8.系列。

#### ! Important: Bed brake pads in! 重要提醒：更換煞車來令片必看

New brake pads only develop their final braking force during the bed-in phase. To do this, accelerate to a speed of 30 km/h on a level road. Use one brake to decelerate to a standstill. Repeat this procedure at least 30 times per brake. Brake pads and rotors have now been run in and will provide optimum braking performance.

安裝全新的來令片需要經過磨合。透過經驗法則，在碟盤與來令片皆為全新的狀況時，請把自行車加速到30km/h後，按壓煞車，重新執行磨合動作至少30次以上。來令片及碟盤經過磨合後，提供最佳的制動狀態。

### RIM BRAKE PADS 輪圈煞車塊

Check your rim type!  
依你使用的輪圈進行挑選

#### BLACK RED

For uncoated aluminium rims.  
適用無塗層的鋁製輪圈

#### GREY GREEN

For hard coated aluminium and ceramic rims.  
適用硬質的鋁製輪圈及陶瓷輪圈



#### BLACK GREY

**High durability** – Whether a day trip or a trip around the world. You'll only have to think about servicing your brake afterwards.

高耐用性 – 無論是一日騎乘或是到全球各地進行長途旅行，你只需要考慮結束後，如何保養你的煞車。

#### RED GREEN

**High braking power** – Your bike is daily in use in all weather conditions. Many traffic lights and stops require the maximum power of your brakes.

高制動力 – 適合每日的單車通勤，能適應各種天氣狀況，在走走停停的交通號誌下，都能發揮強大的煞車力道。

# ORIGINAL SPARE PARTS

## BRAKE PADS

### 高品質原廠補修件：煞車塊與來令片



#### BRAKE PAD 9.P/9.C

來令片 9.P / 9.C

9.P Performance – Brake pad for 4 pistons caliper from MY2015, incl. ECE marking  
9.P 功效型來令片適用於MY 2015年後的四活塞卡鉗，通過ECE認證

Order Number

產品編號

2 701 627

RRP

建議售價

19,90 €

9.C Comfort – Brake pad for 4 pistons caliper from MY2015, incl. ECE marking

2 701 626

15,50 €

9.C 舒適型來令片適用於MY 2015年後的四活塞卡鉗，通過ECE認證



#### BRAKE PAD 8.R/8.P

來令片 8.R / 8.P

8.R Race – Brake pad for 4 pistons caliper from MY2015  
8.R 競賽型來令片適用於MY 2015年後的四活塞卡鉗

Order Number

產品編號

2 701 173

RRP

建議售價

29,90 €

8.P Performance – Brake pad for 4 pistons caliper from MY2015, incl. ECE marking

2 701 628

22,90 €

8.P 功效型來令片適用於MY 2015年後的四活塞卡鉗，通過ECE認證。



#### BRAKE PAD 7.R/7.P/7.C

來令片 7.R / 7.P / 7.C

7.R Race – Brake pad for 2 pistons caliper from MY2012  
7.R 競賽型來令片適用於MY 2012年後的二活塞卡鉗

Order Number

產品編號

2 701 179

RRP

建議售價

24,90 €

7.P Performance – Brake pad for 2 pistons caliper from MY2012, incl. ECE marking

2 701 625

19,90 €

7.P 功效型來令片適用於MY 2012年後的二活塞卡鉗，通過ECE認證。

7.C Comfort – Brake pad for 2 pistons caliper from MY2012, incl. ECE marking

2 701 624

15,50 €

7.C 舒適型來令片適用於MY 2012年後的二活塞卡鉗，通過ECE認證。



#### RIM BRAKE PADS

輪圈煞車塊

Brake pad black for HS11/HS22/HS33

適用於HS11/HS22/HS33的黑色煞車塊

Order Number

產品編號

2 701 576

RRP

建議售價

19,90 €

Brake pad grey for HS11/HS22/HS33

適用於HS11/HS22/HS33的灰色煞車塊

0 321 407

19,90 €

Brake pad red for HS11/HS22/HS33

適用於HS11/HS22/HS33的紅色煞車塊

0 720 423

23,90 €

Brake pad green for HS11/HS22/HS33

適用於HS11/HS22/HS33的綠色煞車塊

0 720 439

23,90 €





# ROTORS 碟盤



## STORM SL.2 風暴超輕SL.2

The lightweight Storm SL.2 rotor combines excellent braking performance with minimal weight.  
結合絕佳制動性與超輕量化

Diameter 尺寸	Weight 重量	Order Number 產品編號	RRP 建議售價
160 mm	100 g	2 701 348	35,00 €
180 mm	118 g	2 701 349	35,00 €



## STORM HC INCL. ABE ABE 風暴HC (通過ABE認證)

The Storm HC rotor is designed for extreme use – and provides best braking performance even under large braking forces.

專為極端操駕設計，風暴HC提供你無與倫比的制動性能表現。



Diameter 尺寸	Weight 重量	Order Number 產品編號	RRP 建議售價
160 mm	121 g	2 700 928	30,00 €
180 mm	140 g	2 700 929	30,00 €
203 mm	173 g	2 700 930	30,00 €



## STORM CL 風暴CL

The new two-part Storm CL rotor for high braking performance at high loads. Equipped with a centerlock mount for corresponding hubs.

全新推出二件式中心鎖固式碟盤Storm CL，在高負載下能夠實現高制動性能，同樣配有相對應中心鎖。

For quick-release-axle incl. lockring 快拆式鎖固，包含鎖固環

Diameter 尺寸	Weight 重量	Order Number 產品編號	RRP 建議售價
160 mm	194 g	2 701 370	35,00 €
180 mm	221 g	2 701 371	35,00 €
203 mm	253 g	2 701 372	35,00 €

For thru axle inc. lockring 心軸式鎖固，包含鎖固環

Diameter 尺寸	Weight 重量	Order Number 產品編號	RRP 建議售價
160 mm	196 g	2 701 446	35,00 €
180 mm	223 g	2 701 447	35,00 €
203 mm	255 g	2 701 448	35,00 €

# ORIGINAL SPARE PARTS

## SERVICE PRODUCTS

### 維修保養產品



#### ROYAL BLOOD 皇家血統礦物油

MAGURA Royal Blood, 100 ml  
MAGURA Royal Blood, 250 ml  
MAGURA Royal Blood, 1000 ml

#### Order Number 產品編號

0 721 630  
0 721 632  
0 721 631

#### RRP 建議售價

6,50 €  
17,50 €  
33,50 €



#### FORK MEISTER GREASE 避震前叉潤滑油膏

for bushings from MY 2012  
適用於MY 2012年後的襯套潤滑

#### Order Number 產品編號

0 724 807

#### RRP 建議售價

24,90 €



#### SUSPENSION BLOOD 避震前叉油品

Suspension Blood Typ 2 SAE 5ISOVG 25, damping oil,  
500 ml  
避震前叉專用阻尼油：500ml

#### Order Number 產品編號

0 731 120

#### RRP 建議售價

13,90 €

# SERVICE PRODUCTS



## SERVICE KIT 維修保養組

Service Kit (for disc and rim brakes), Contents:  
100 ml Royal Blood, 2 × syringes incl. hose, Torx T25,  
2 × installing clamps, small parts and inserts for hose  
shortening

維修保養配件包適用於液壓碟煞及輪圈煞。內含：100ml  
皇家血統礦物油、2個注油針筒及軟管、T25星型螺絲起子  
、2個安裝固定座、剪管用的油針及小零件。

Order Number 產品編號	RRP 建議售價
2 700 191	33,00 €



## PROFESSIONAL BLEED KIT 專業灌油組

Professional bleed kit (for disc and rim brakes),  
contents: Syringe, hose with EBT filling plug, hose  
with thread attachment, 250 ml plastic bottle includ  
ing hook, 250 ml Royal Blood

專業煞車維修配件包適用於液壓碟煞及輪圈煞。內含：注  
油針筒、搭配EBT接頭軟管、搭配有牙紋的轉接頭軟管、  
250ml配有掛勾的塑膠油壺、250ml皇家血統礦物油。

Order Number 產品編號	RRP 建議售價
0 724 492	46,90 €



## VYRON BLEED KIT VYRON灌油組

VYRON bleed kit, contents: Filling needle incl. adapter,  
shut-off valve, 3 mm allen key (long)

VYRON灌油組，包括含轉接頭灌油連接工具、開關閥門及  
三號內六角扳手（長）

Order Number 產品編號	RRP 建議售價
2 701 404	79,90 €





MAG  
since 1893

A person's arm is visible on the left side of the frame, wearing a white and grey baseball-style shirt. The background is a dark, textured wood grain. The word "APPAREL" is written in large, white, bold, sans-serif capital letters across the center of the image. A thick, bright yellow diagonal slash cuts through the word, starting from the top right of the 'P' and ending at the bottom left of the 'L'.

**APPAREL**

URA



# APPAREL

## 1893 BIKE- AND STREETWEAR

### 潮炫酷型：MAGURA專屬人身部品

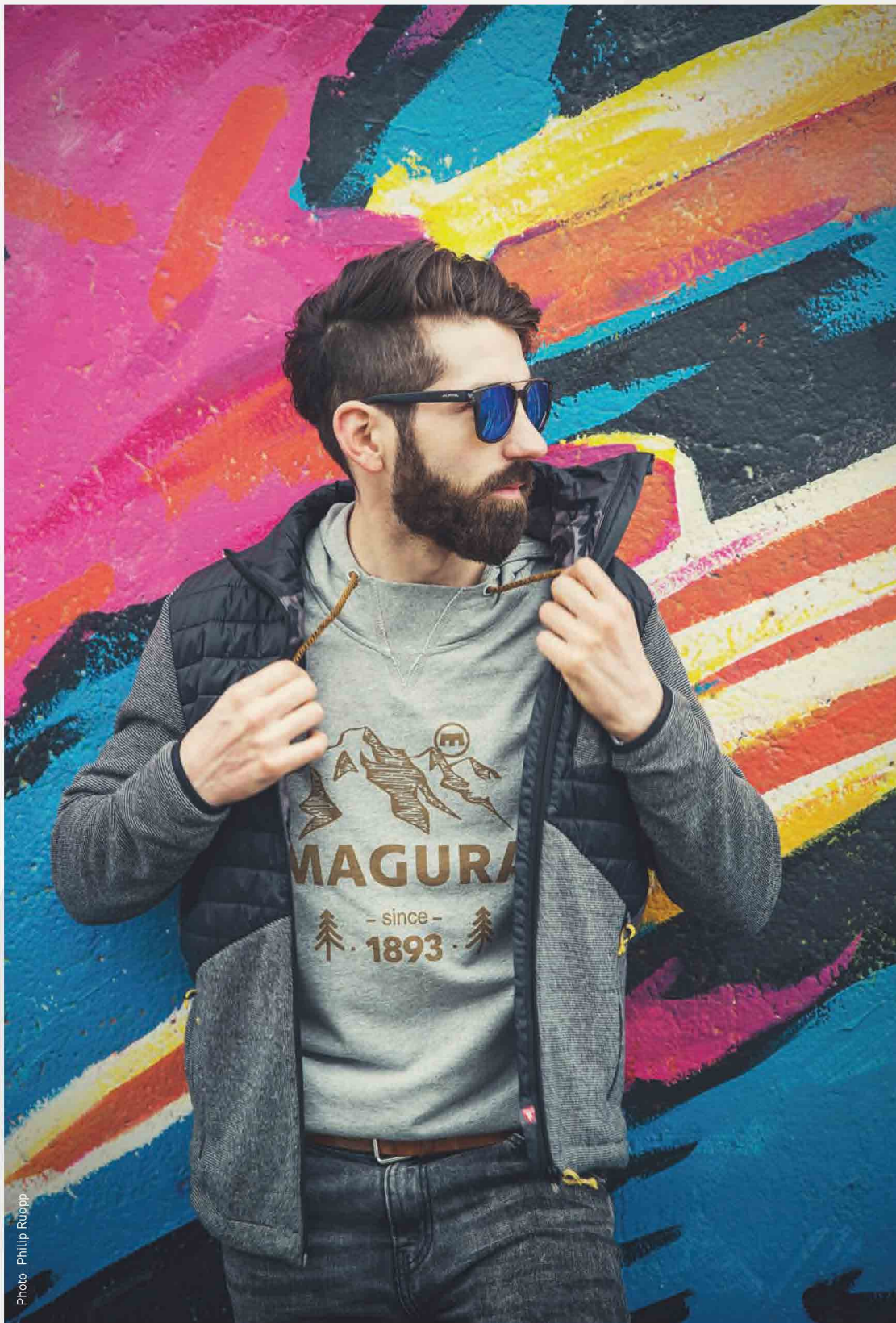

Photo: Philip Ruopp



**MAGURA**

*maloja*



# STREETWEAR

## 街頭服飾



Photo: Philip Rucopp



### MAGURA 1893 T-Shirt Men/Women

MAGURA 1893 T-Shirt 男款 / 女款

The 1893 shirt for men and women is loosely cut and made of organic cotton. Finished with the image of the Ermstal – where MAGURA is based – the shirt is particularly eye-catching.

MAGURA 1893 男女款皆T恤皆使用寬鬆剪裁，並採用有機棉製成，圖案明白表現出MAGURA根據地Erristal的鄉野風光。

**Style 風格:** Men 男款 / Women 女款  
**Sizes 尺寸:** 男款S – XXL / 女款XS – XL  
**RRP 建議售價:** 44,00 €

### MAGURA 1893 Street Hoodie

MAGURA 1893 街頭連帽衫

The hoodie is made of 100% cotton finished with a high-quality print. Thanks to the collar, it is comfortable to wear all year round.

連帽衫採用100%純棉製成，圖飾採用高品質印製，一年四季都穿著舒適。

**Style 風格:** Unisex 男女皆宜  
**Sizes 尺寸:** XS – XXL  
**RRP 建議售價:** 79,00 €



### MAGURA 1893 Hybrid Jacket

The Hybrid jacket is made of a high-grade wool blend on the outside and soft fleece on the inside. Thanks to the Primaloft inserts on the chest and back, it is the perfect companion on cooler days.

Hybrid夾克採用高檔羊毛混紡布料製成，內側採用柔軟羊毛製成。在胸部及背部加入Primaloft保暖棉材質，即使潮濕環境也能擁有優異的保暖效果，是在涼爽的日子裡的完美伴侶。

**Style 風格:** Unisex 男女皆宜  
**Sizes 尺寸:** XS – XXL  
**RRP 建議售價:** 199,00 €

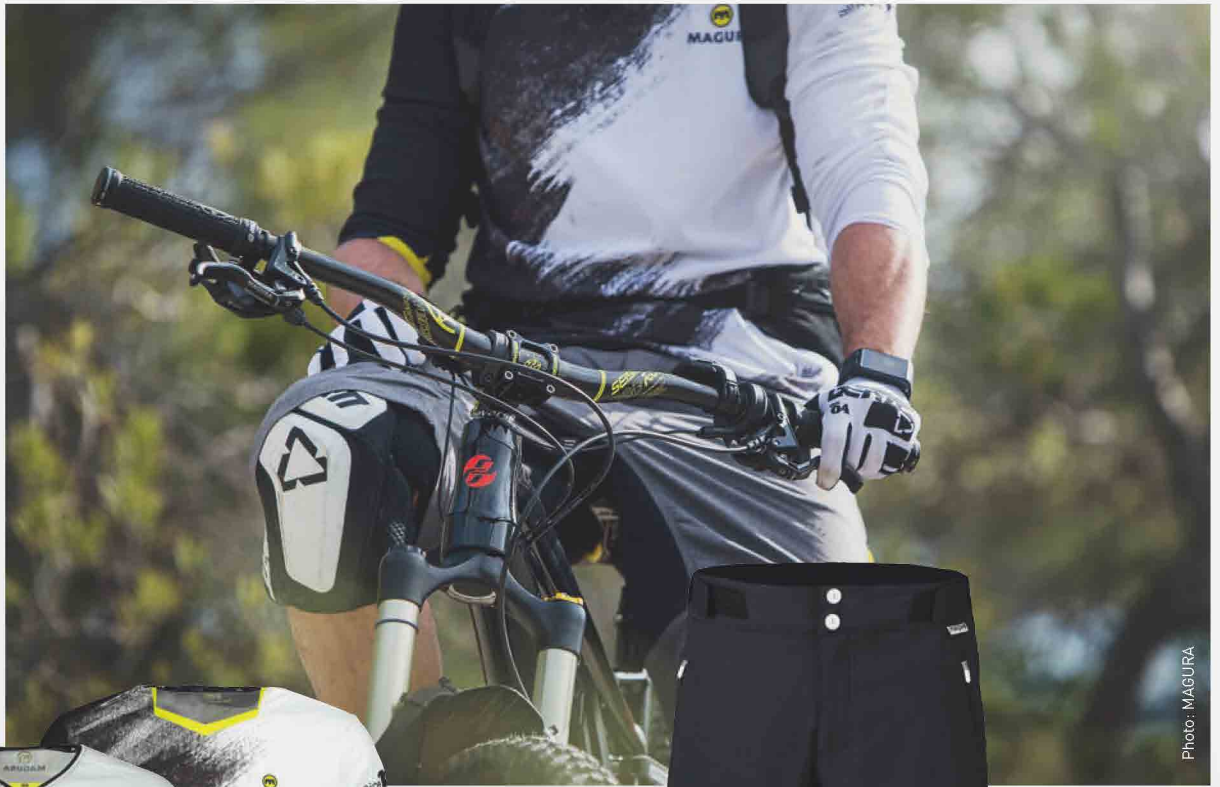

Photo: MAGURA



**MAGURA 1893 Jersey**  
**MAGURA 1893 Jersey Longsleeve**  
MAGURA 1893短袖運動衫  
MAGURA 1893長袖運動衫

Bike jersey made of highly functional Airdry material. The jersey stays fresh and odour-free thanks to Polygiene technology. Longsleeve: with an integrated cleaning cloth for goggles inside the garment.

Style 風格: Unisex 男女皆宜  
Sizes 尺寸: S - XXL  
RRP 建議售價: 76,00 € / 99,00 €



**MAGURA 1893 Short**  
MAGURA 1893 短褲

These bike shorts made of polystretch material stretch flexibly with every movement in any sports, not only biking, thanks to their stretch insert in the rear waistband.

由聚合物材料製成的自行車短褲，腰部採用鬆緊帶，讓你在各種運動的每一個動作，都能靈活伸展。

Style 風格: Unisex 男女皆宜  
Sizes 尺寸: XS - XXL  
RRP 建議售價: 84,00 €

**MAGURA 1893 Sports Socks Low/Mid**  
MAGURA 1893運動襪 低筒 / 中筒

These sports socks (low/mid) have Quick Dry Technology and wide, elastic ankle cuffs made of Microlon fabric, making them extremely comfortable.

單車運動襪（低筒 / 中筒）採用Quick Dry技術，踝部袖口採用Microlon布料製成，具有寬鬆彈性、舒適之感。



Style: Unisex  
Größen Sizes: 36-46  
UVP RRP: 12,00 € / 14,00 €

Style 風格: Unisex 男女皆宜  
Sizes 尺寸: 36-46  
RRP 建議售價: 12,00 € / 14,00 €

**BIKEWEAR**  
單車服飾

More information about the products: [www.magura.com](http://www.magura.com)  
更多產品訊息請上: [www.magura.com](http://www.magura.com)



# APPAREL

## RIDE & RELAX

### 休閒騎乘人身部品

.....

#### RIDE Bikewear

單車騎乘



MAGURA Gravity Series Short  
MAGURA 重力系列短褲



MAGURA Gravity Series Jersey  
MAGURA 重力系列運動衫



MAGURA Gravity Series Jersey  
Longsleeve  
MAGURA 重力系列長袖運動衫



MAGURA Trail Series Jersey  
MAGURA 林道系列運動衫

.....

#### RELAX Streetwear

休閒街頭服飾



MAGURA Smoke Jersey  
Longsleeve  
MAGURA 煙霧長袖運動衫

STYLED BY  
MALOJA & MAGURA

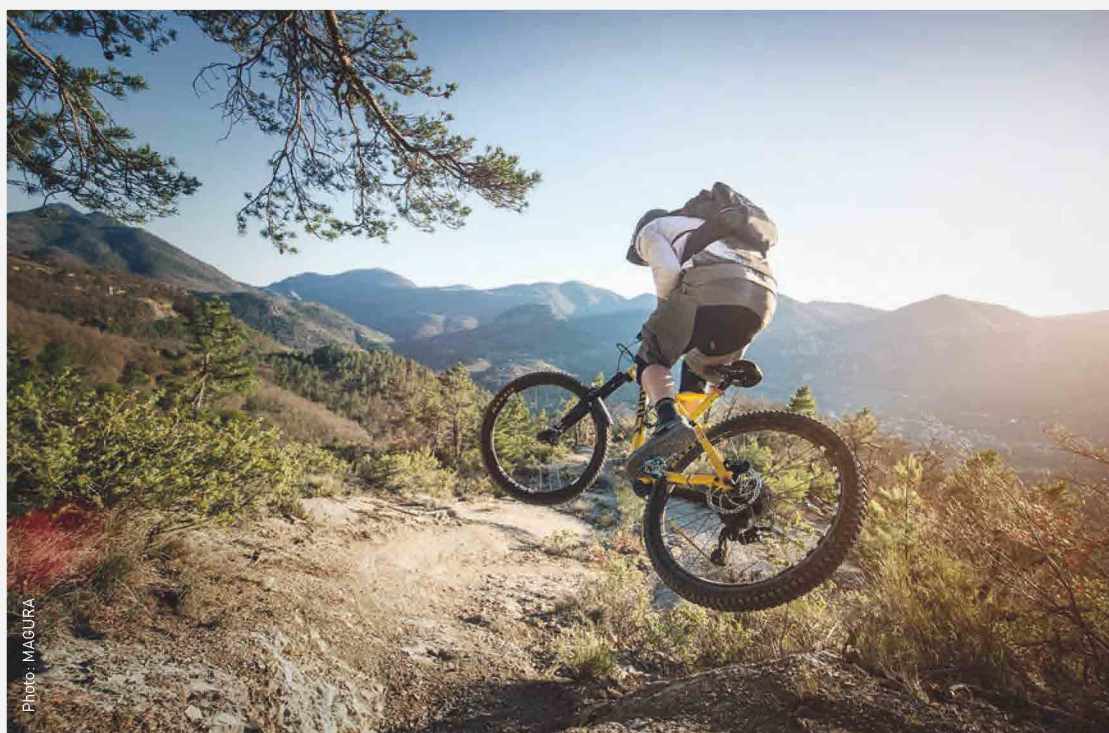

Photo: MAGURA





Behrig Twins



Hannee Slavik



Max Schumann



Halbikre Enduro Crew



Kate Courtney

# SPONSORED RIDERS AND TEAMS 贊助運動員及車隊

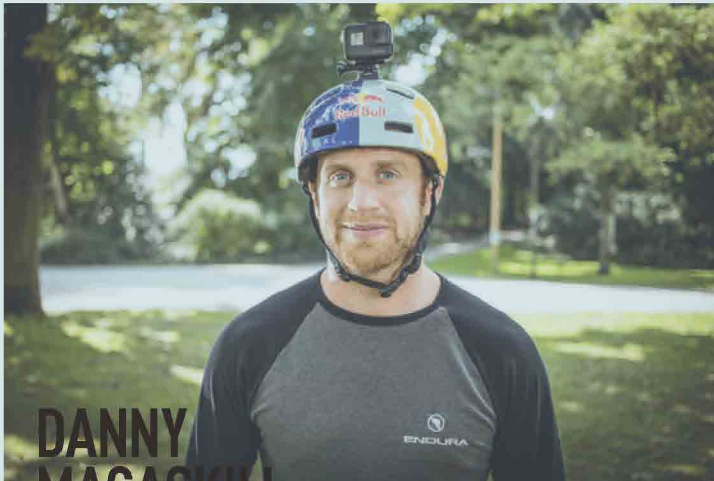

**DANNY  
MACASKILL**

**NICK NAME 綽號**

Danny / DMAC 丹尼大神

**DISCIPLINE 專長項目**

Street Trial, Mountain Biking  
各式神技大招精彩展現、登山車

**FAVORITE MAGURA PRODUCT**

最愛的MAGURA產品  
MT7 Raceline

**SPONSORED MAGURA RIDER SINCE**

MAGURA開始贊助年份  
2015

**YOUR MAGURA MOMENT**

專屬的MAGURA黃色記憶

As a kid, all my heros rode MAGURA brakes and now 15 years later having my own MAGURA signature brake in neon yellow.

小時候，我所崇拜的英雄們都使用MAGURA的煞車。長大後，沒想到我能擁有MAGURA合作的煞車，以及標誌性的霓虹黃卡鉗。

## AWESOME RIDERS AND FRIENDS!

**NICK NAME 綽號**

The Director of Good Times,  
Tip, Tiptronica 好時光製造機

**DISCIPLINE 專長項目**

Freeride 自由騎

**FAVORITE MAGURA PRODUCT**

最愛的MAGURA產品  
MT7

**SPONSORED MAGURA RIDER SINCE**

MAGURA開始贊助年份  
2016

**YOUR MAGURA MOMENT**

專屬的MAGURA黃色記憶

When I realised the huge braking performance of the MAGURA brakes – even on long descents. Hanging out with the MAGURA staff on events is always fun.

煞車超強制動性能，即使長時間在下坡騎乘也能保有強強制動力，是對MAGURA印象最深記憶。另外與MAGURA的工作人員一起參加活動，總是感到非常有趣。

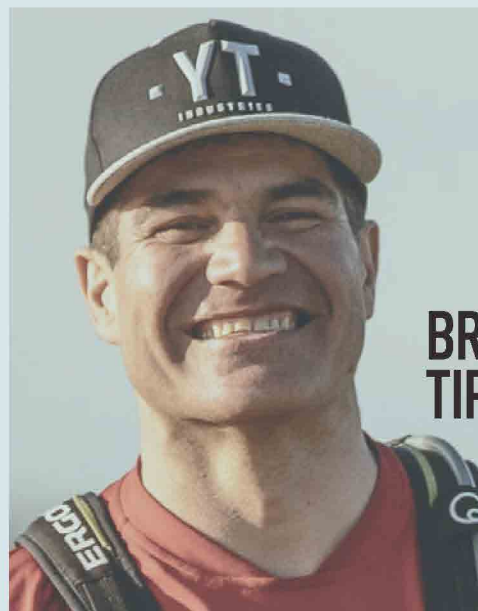

**BRETT  
TIPPIE**

READY FOR THE  
NEXT CHALLENGE



**LOIC  
BRUNI**

**NICK NAME** 綽號  
SuperBruni  
超級布魯尼

**DISCIPLINE** 專長項目  
Downhill  
下坡車 (二屆世錦賽冠軍得主)

**FAVORITE MAGURA PRODUCT**  
最愛的MAGURA產品  
MT7

**SPONSORED MAGURA RIDER SINCE**  
MAGURA開始贊助年份  
2018

**YOUR MAGURA MOMENT**  
專屬的MAGURA黃色記憶

At the end of 2017 I tried the MAGURA brake for the first time. It was raining and muddy – however the brake performance of the MT7 was always high during all the runs. The brake convinced me immediately.

2017年底，我第一次嘗試了MAGURA煞車。當時騎乘環境是雨天且和路面泥濘，然而MT7在如此惡劣環境下，制動性能始終保持高品質，馬上說服了我...就是這個煞車！

**NICK NAME** 綽號  
Whipmer, Flipmer  
創意製造機、大製片家

**DISCIPLINE** 專長項目  
Street Trial, Downhill, Freeride  
各式神技大招精彩展現、下坡車、自由騎

**FAVORITE MAGURA PRODUCT**  
最愛的MAGURA產品  
MT7

**SPONSORED MAGURA RIDER SINCE**  
MAGURA開始贊助年份  
2016

**YOUR MAGURA MOMENT**  
專屬的MAGURA黃色記憶

Every single day is a MAGURA moment for me. As a trial biker I push my MT7 to the limit every day – and it could all go terribly wrong if they didn't work. Thankfully I can trust in my brakes every day.

每一天對我來說都是難忘的MAGURA時刻。我每天都嘗試不同方法，把我的MT7推向極限，MAGURA剎車讓我可以精準展現想要做的風格及動作。

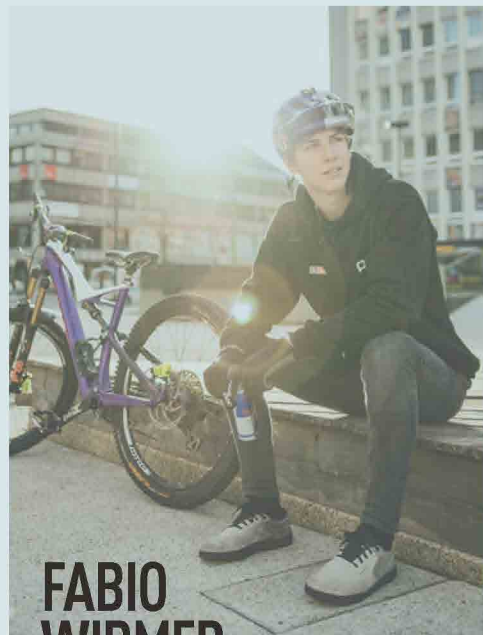

**FABIO  
WIBMER**



## YANA BELOMOINA



**NICK NAME** 綽號

Miss Belomoina  
驚騎女超人

**DISCIPLINE** 專長項目

Cross Country  
越野車

(2017年UCI XCO World Cup菁英女子組積分后)

**FAVORITE MAGURA PRODUCT**

最愛的MAGURA產品  
MT8 Raceline

**SPONSORED MAGURA RIDER SINCE**

MAGURA開始贊助年份  
2013

**YOUR MAGURA MOMENT**

專屬的MAGURA黃色記憶

Winning my first World Cup in Albstadt in 2017. I could always count on my MT8 Raceline – even though I didn't have to use it that much in this race.

賽場神隊友MT8協助我在2017年UCI XCO World Cup德國站，贏得人生第一場World Cup賽事，不僅是個人車涯第一次World Cup冠軍，也是有史以來，首位稱霸UCI XCO World Cup的烏克蘭烏克蘭選手。

**NICK NAME** 綽號

Porter 波特王

**DISCIPLINE** 專長項目

Freeride 自由騎

**FAVORITE MAGURA PRODUCT**

最愛的MAGURA產品  
MT7 and VYRON

**SPONSORED MAGURA RIDER SINCE**

MAGURA開始贊助年份  
2017

**YOUR MAGURA MOMENT**

專屬的MAGURA黃色記憶

Riding the White Line trail in Sedona last year at the MAGURA Press Camp. I have 100 % trust in my brakes as my life often depends on them.

2017年開始接觸到MAGURA煞車，自此之後，我相信生命中無法沒有MAGURA的煞車...

## ERIC PORTER

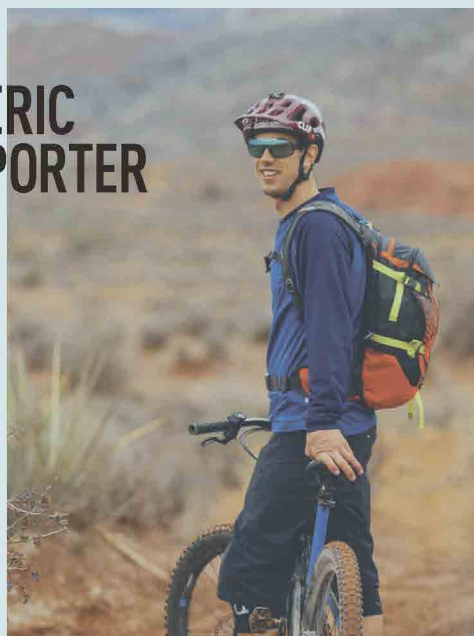

## MORE RIDERS & TEAMS

### 更多車手及車隊

Specialized Enduro Team, Specialized Racing XC Team, Guido Tschugg, Jasper Jauch, Hannes Slavik, Lac Blanc-Commencal, Team BH-SR Suntour-KMC, Kreidler Werksteam, Max Schumann, André Wagenknecht, Morgane Such/Quentin Champion ROTWILD Factory Team, Stefan Schlie, Greta Weithaler, German Technology Racing Team, Haibike Enduro Crew, FS Patrol Funn, Claire Buchar/Chris Kovarik Intense, Solid-Reverse Factory Racing, EVO Bike Park, Marcus Klausmann, David Erstling, Laura Brethauer, Harald Philipp, Jordan Baumann, Jeremy Struik, Lizzy Witlox, Iris van der Pol, Annika Jeschke, Philipp Foltz/Atlantic Cycling, Stefan Herrmann/MTB-Academy, Philip Walder, Tino Käßner, GZ-Racing, Dorothee Fleck, Andreas Kromer, BPA Racing, Cycle for a better world.

ASIAN Athletes

亞洲贊助運動員



## Team Chiru MAGURA

**NICKNAME** 綽號  
KK、坤哥、坤坤

**DISCIPLINE** 專長項目  
TRIAL, MTB

**YOUR MAGURA MOMENT**  
專屬的MAGURA黃色記憶

MAGURA陪伴著張京坤成長、追夢，在15歲進入攀爬車領域，靠著自身苦練成為紀錄保持人，現在張京坤更積極投入騎乘教學、影音拍攝...等，把自行車魅力傳遞給每個人們。



## 張京坤



## 宜蘭自由車 培訓隊

**ATHLETES**

運動員

Tugulduur Tuulkhantai, Myriam Guillot-Boisset, Jacky Boisset, Pierre A. LeMagnan, Kurt Lynn, Joachim Mendler, Fraser Young, Tao Quemere, Mendler Joachim JoaKinator, Antonin Marecaille, Frederic Gombert, Nicolas Cambus, Sophie Giovane

**DISCIPLINE** 專長項目

MTB, ENDURO, XC

**YOUR MAGURA MOMENT**

專屬的MAGURA黃色記憶

Team Chiru MAGURA運動員們足跡遍及全球，把自行車與生活完全結合，同時熱情挑戰自我並勇於突破每道關卡，Team Chiru MAGURA就是這麼酷！

**ATHLETES** 運動員

陳姿吟、周璇、葉羽霜、何翊慈、何彥誼、楊承祐、簡佑安...等

**DISCIPLINE** 專長項目

MTB

**YOUR MAGURA MOMENT**

專屬的MAGURA黃色記憶

由MAGURA ASIA公益贊助的宜蘭自由車培訓隊，希望能藉此機會拋磚引玉，培養更多自行車的希望種子，並且在推廣自行車文化及運動，傳遞更多正向力量。



# PRODUCT TABLE: BRAKES

		MT7 PRO	MT5	MT TRAIL SL	MT TRAIL SPORT	MT8 SL	MT8 PRO	MT4	MT SPORT	HS33	HS22	HS11
<b>Applications</b> 適用車種	MTB 登山車	●	●	●	●	●	●	●	●			
	Trekking/City 城市休閒車							●	●	●	●	●
	S-Pedelecs [e] 高速電動自行車		●[e]					●[e]		●[e]		
	E-Bike 電動自行車	●	●	●	●	●	●	●	●	●	●	●
<b>Weight (g)</b> 重量	MT/IS 側鎖式卡鉗	255 <sup>B</sup>	255 <sup>B</sup>	230 <sup>A</sup>	245 <sup>A</sup>	195 <sup>B</sup>	225 <sup>B</sup>	230 <sup>B</sup>	245 <sup>B</sup>	480 <sup>C</sup>	480 <sup>C</sup>	435 <sup>C</sup>
	Flatmount 平裝式卡鉗					185 <sup>B</sup>		220 <sup>B</sup>				
<b>Material</b> 材質	Caliper 卡鉗	Aluminium 鋁合金	●	●	●	●	●	●	●	●	●	●
	Master 本體	Carbotecture SL <sup>®</sup> 高科技碳纖維複合材質	●		●	●	●					
		Carbotecture <sup>®</sup> 獨家纖維複合材質		●	●			●	●	●	●	●
	Lever blade 拉柄	Carbon 碳纖維			●	●						
		Carbotecture <sup>®</sup> 獨家纖維複合材質							●		●	●
		Aluminium 鋁合金		●				●		●		
		Hollow Aluminium 中空鋁合金	●		●	●						
<b>Lever blade</b> 拉柄	1-Finger HC 單指HC拉柄	●		●	●	●	●					
	2-Finger 2指拉柄		●					●	●	●		
	3-Finger 3指拉柄										●	●
	3-Finger ball-end 3指球型拉柄		●[e]					●[e]		●[e]		
<b>E-Bike Schalter</b> 電動車斷電開關			●[e]					●[e]		●[e]		
<b>Features</b> 技術特點	EBT 易注油技術	●	●	●	●	●	●	●	●	●	●	●
	BAT/TPA 煞車靈敏度/ 煞車塊間隙調整	●								●	●	
	Brake Booster 煞車補強片									●	●	
	Caliper 卡鉗	●	●	●	●	●	●	●	●			
	2 Pistons 二活塞			● rear	● rear	●	●	●	●			
	4 Pistons 四活塞	●	●	● front	● front							
	Reach Adjust 握距調整									●		
	with tool 需要工具		●	●	●	●	●	●	●	●		
	toolless 免工具	●					●				●	
	Flip-Flop 左右共用	●	●	●	●	●	●	●	●	●	●	●
	Shift Mix 整合式固定環	opt.	opt.	opt.	opt.	opt.	opt.	opt.	opt.	opt.	opt.	opt.
<b>Rotor<sup>D</sup></b> 碟盤D	Storm SL.2 風暴SL.2					●	●					
	Storm HC 風暴HC	●	●	●	●			●	●			
<b>Mounting</b> 卡鉗固定座	PM/IS 正鎖式/側鎖式	●	●	●	●	●	●	●	●			
	Flatmount 平裝式					●		●				
	Canti									●	●	●
<b>Brake pad mounting</b> 來令片安裝	Magnet with screw 磁吸式有螺絲	●	opt.	●	● rear	●	●	●	●			
	Magnet without screw 磁吸式無螺絲	opt.	●	opt. front	● front							
	HS EPR									●	●	●
<b>Hydraulic</b> 液壓		●	●	●	●	●	●	●	●	●	●	●
<b>Brake medium</b> 煞車油媒介	Royal Blood 皇家血統礦物油	●	●	●	●	●	●	●	●	●	●	●
<b>Tubing</b> 油管	MAGURA disc tube	●	●	●	●	●	●	●	●			
	MAGURA tube									●	●	●
<b>RRP/€<sup>E</sup></b> 建議售價		219,90	109,90	579,90 [Set]	219,90 [Set]	279,90	179,90	89,90	59,90	109,90	89,90	69,90

» All given weights +/- 2% 重量在提供數據±2% 為正常

» Compatible with standard Shimano STI, SRAM Trigger, SRAM and Rohloff twist-grip shifters  
相容標準Shimano STI, SRAM Trigger, SRAM 和 Rohloff 扭轉手柄變速器

» 5-year leak proof guarantee on masters and calipers

MAGURA針對提供合法購買證明之第一手買主提供獨家煞車本體及卡鉗五年防漏保固  
自購買日起五年內有效。煞車油管並不在五年防漏保固的範圍內！

» Product specifications are subject to change without prior notice

產品規格如有更改，恕不另行通知

» <sup>A</sup> Average weight of front and rear brake

前後煞車平均重量

» <sup>B</sup> Weight per brake, without rotor, without adapter

不含碟盤及轉接座的煞車重量

» <sup>C</sup> Weight per brake 煞車重量

» <sup>D</sup> Recommendation 建議

» <sup>E</sup> Without rotor, without adapter 無碟盤及轉接座



# MAGURA NETWORK

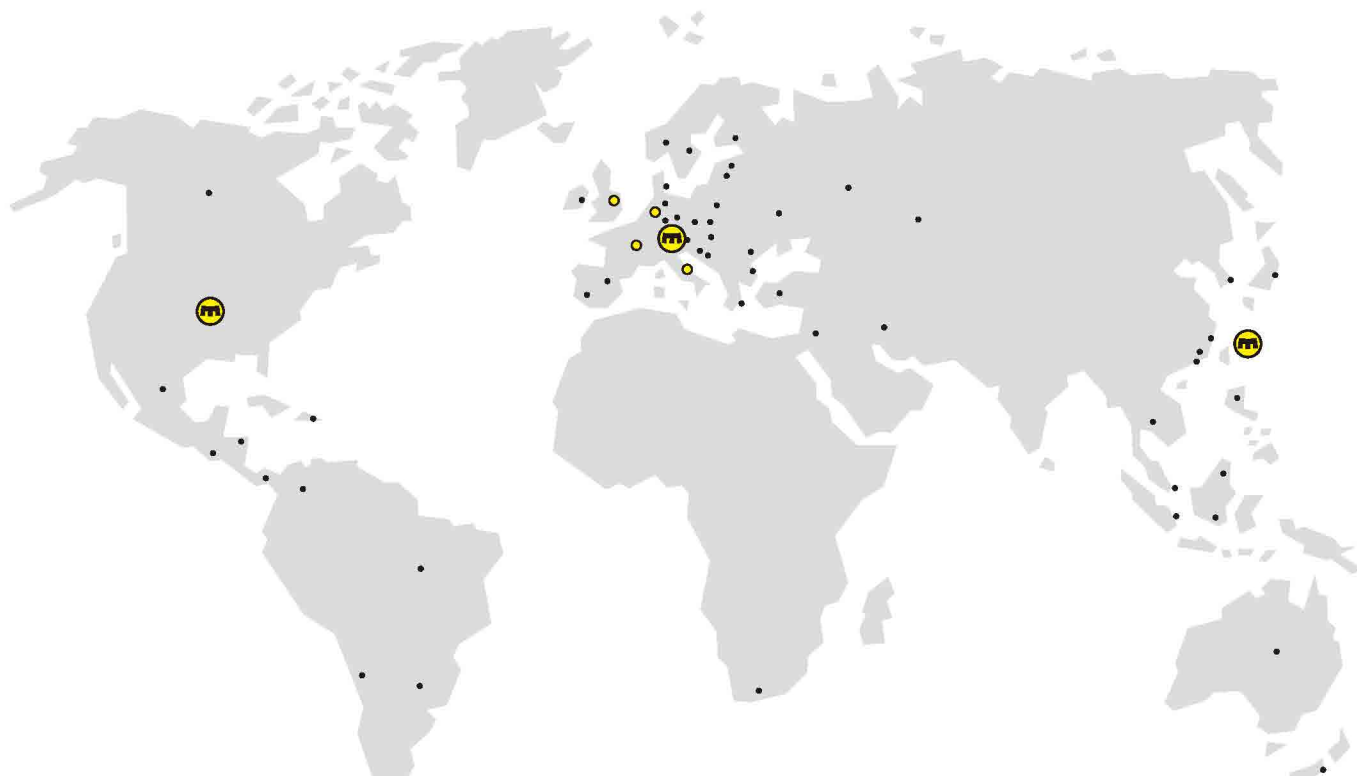

## MAGURA

MAGURA ASIA LIMITED CO.  
No.9, Industrial Park 10th Road,  
Taichung City, 40755 Taiwan  
Phone: +886-4-2359-8555  
Fax: +886-4-2359-9910  
[www.magura.com.tw](http://www.magura.com.tw)  
[facebook.com/maguraasia](https://facebook.com/maguraasia)

德國瑪古拉企業集團  
瑪古拉亞洲有限公司  
台中市西屯區工業區十路9號  
電話: +886 4 2359 8555  
傳真: +886 4 2359 9910  
[www.magura.com.tw](http://www.magura.com.tw)  
[facebook.com/maguraasia](https://facebook.com/maguraasia)

© MAGURA, All rights reserved  
規格如有變更，恕不另行通知  
Features may be subject to change