



ABOUT MAGURA 4

關於瑪古拉

PRODUCT OVERVIEW 8

產品總覽

PRODUCT SEGMENTS 10

產品分類

TRAIL SERIES 林道系列	10
COMPETITION SERIES 競速系列	12
GRAVITY SERIES 重速系列	14
SPEED eMOBILITY SERIES 電動車/電助車系列	16
MULTI USE SERIES 多功能系列	18

MAGURA TECHNOLOGY 20

瑪古拉工藝技術

MT TRAIL CARBON MT TRAIL 碟煞	20
eLECT CONNECTIVITY eLECT 智能連接	22
MAGURA ORIGINAL SPARE PARTS 瑪古拉正廠零配件	24

PRODUCT CATEGORIES 26

產品範疇

DISC BRAKES 油壓碟煞	26
RIM BRAKES 油壓輪圈煞	32
E-BIKE BRAKES 電動車系列煞車	38
SEATPOST 無線伸縮座管	42
SUSPENSION 避震前叉	43

BRAKE PADS 48

來令片

SPARE PARTS 50

補修零配件

MOUNTING GUIDE 安裝指南	53
---------------------	----

APPAREL 56

人身部品

SPONSORED RIDERS 60

贊助車手

MAGURA 2017 CHANGING THE GAME

Back in 1987, when MAGURA manufactured the first hydraulic rim brakes for bicycles, a new field opened up. The legendary, neon yellow HS22 changed the face of mountain biking and racing. And the best racers in the world used the products, Jürgen Beneke, Regina Stiefl and Olympic champion Bart Brentjens. John Tomac even received a signature model in signal red. Since then, MAGURA has constantly developed new technologies and innovative products: the first hydraulic disc brake for mountain bikes, Gustav M. The "Swabian stopper" became a legend. MAGURA combines tradition and progress. Germany as a country boasts outstanding engineers and technologies, making possible a continuous cycle of optimization.

We work hard to continually develop our products, a fact that is acknowledged by the numerous best-in-test awards in the trade press, the best acknowledgment and a constant motivation for our team. Our highlights: VYRON, the first wireless remote dropper seatpost. The entire MT disc brake series, which benefits from the innovations of the MT7 and the MT8, such as our own material development, Carbotecture SL, there's less weight yet at the same time resistant to extreme loads. And now in the era of the electric bike, our specially developed models take full advantage of MAGURA's motorbike know-how. Reliable brake systems control brake lights and the automatic switch off of the power unit.

And, as we have been doing since the 1990s, we still work closely together with the top athletes, who can use our products at their limits and beyond. When YouTube star Danny MacAskill risks his neck in daredevil stunts, he's putting his trust in MAGURA. Other riders and testers include freeride icon Brett Tippie, bike legends Shaun Palmer and Cédric Gracia, Olympic champion Sabine Spitz, who will be competing in her fourth Olympic Games in Rio using MAGURA, downhill World Cup rider Johannes Fischbach and Harald Philipp bike alpinist all use MT disc brakes.

As long as athletes are constantly redefining the rules of the game, we at MAGURA will stay motivated to develop the products to match. When did you last change your game rules?
MAGURA – Changing the game.



Photos: Nathan Hughes



PASSION SINCE
1893



1987年，當瑪古拉成功產出市場上第一套自行車專用的液壓輪圈煞車，從此開啟自行車產品的全新領域。傳說中，瑪古拉霓虹黃HS22輪圈煞，改變了現今登山車及越野賽事的樣貌。產品廣受世界級車手，如Jürgen Beneke、Regina Stiefel和奧運冠軍Bart Brentjens的青睞，甚至特別為傳奇登山車手John Tomac打造了光澤閃耀的紅銅色簽名版煞車。從那時起，瑪古拉便致力研發革新技術與產品創新：第一套運用於登山車的液壓碟煞：Gustav M，是道道地地在史瓦本出產的制動器“Swabian stopper”，成為一代經典傳奇。瑪古拉結合傳統的優良根基，要持續邁向卓越。德國，以擁有豐厚的工程人才和專業的技術底蘊而自豪，有此背景支持，讓我們能不斷改善提升，繼續向前邁進。我們致力精進我們的產品，並在媒體評測中多次獲得最佳產品的殊榮，對團隊，不僅是最棒的鼓勵，也激勵我們要不斷向前！近期的產品亮點：市場上第一支無線伸縮座管VYRON。整個MT碟煞系列，受益於MT7及MT8的創新產品技術，如：產品線運用獨家開發的高科技材料Carbotecture SL精心打造，重量超輕卻相當堅固耐用。

面對這波電動自行車的時代大潮，瑪古拉早已站穩腳步，以常年累積於重型摩托車的專業技術與經驗為優勢，開發一系列適用於電動自行車的產品。性能可靠的煞車系統，可控制煞車燈以及截斷電控馬達。此外，我們從90年代起，就與世界頂尖的運動員保持密切的合作關係，使用我們的產品不斷超越極限之巔。當YouTube的超級明星Danny MacAskill挑戰各種高難度特技時，代表這位街舉大師對瑪古拉產品的充分信任。其他專業車手和測試車手，包括著名的自由騎車手Brett Tippie、傳奇登山車手Shaun Palmer和Cédric Gracia、奧運常勝軍Sabine Spitz，在她第四度參與奧運盛事中，於里約奧運選用瑪古拉產品配備戰駒、世界盃下坡賽好手Johannes Fischbach和極限運動登山車手Harald Philipp，都有志一同地選用MT油壓碟煞系統。只要這些運動員們敢勇於挑戰自我極限，甚至改變遊戲規則，瑪古拉也將更積極地尋求新的突破，開發與之匹配的優質產品。您上一次，挑戰自我是什麼時候呢？跟著瑪古拉一起 - 突破規限、開闢新局面吧！

MAGURA

CHANGING THE GAME

DAMALS UND HEUTE: SCHEIBENBREMSEN

1997 vs. 2016

Mit der M
die wohl
hat sich
legendär



Der Bremssattel

Die legendäre Gustav M ist eigentlich die Mini-version einer Motorradbremse. Damit die Bremsbeläge der Zweikolbenbremse (zwei pro Bremssattel, parallel) den gleichen Abstand links wie rechts halten, besitzt die Gustav einen **schwimmend** gelagerten Sattel. Dieser zentriert sich durch den Kontakt zur Scheibe, war daher aber kaum schleiffrei einstellbar. Ganz anders die neue MT7. Sie verzögert mit einem **Festsattel**, der vier Bremskolben besitzt.

Die Befestigung

Als die Gustav M 1997 auf den Markt kam, gab es diverse Befestigungsarten für den Bremssattel. Im Jahr 2000 etablierte sich der **International Standard 2000** („IS“), der über Jahre verwendet wurde. Die MT7 wird via **Postmount**-Befestigung an Rahmen oder Gabel geschraubt. „PM“ wurde von Gabelhersteller Manitou erfunden, ist heute etabliert und erleichtert die Ausrichtung des Sattels deutlich.

Der Bremshebel

Die großen Bremshebel der Gustav M dienten in den Neunzigern dazu, sie wie damals üblich mit mehreren Fingern zu betätigen. Doch gerade so ein Wurfanker wie die Gustav legte den Grundstein für den Einfingerhebel. Dieser ist an modernen Bremsen wie der MT7 nicht mehr wegzudenken, da die Bremskraft so perfekt dosiert werden kann. Viele Hebel bieten heute eine Verstellung von Druckpunkt und Hebelweite – oft sogar werkzeuglos. Ein gut sichtbarer Unterschied der beiden Maguras: Die Gustav M besitzt eine **axiale** Ansteuerung der Bremspumpe, die MT7 eine **radiale**. Die zweiteilige Schelle am Hebel gab es bereits bei der Gustav M, bei der modernen MT7 kann an die Schelle optional ein Sram-Schalthebel angedockt werden.*

Die Scheibe

An den frühen Gustav-M-Modellen diente eine **Alu-Scheibe** als Reibpartner. Da sich Alu bei Hitze jedoch stark ausdehnt, war der Reibring schwimmend gelagert. So konnte sich die Scheibe ausdehnen, ohne sich zu deformieren. Wie bei den meisten modernen Bremsen setzt die MT7 auf eine **Stahl-Scheibe**. Diese leitet die Hitze besser ab. Das wellige Design der Storm-Discs brachte Magura erstmals 2002. Es spart Gewicht, sticht optisch hervor. Während es für die Gustav M 1997 nur 160-mm- und 190-mm-Rotoren gab, haben sich heute die Größen 140, 160, 180 und 200 (203) mm etabliert. Der Lochkreisabstand der 6-Loch-Discs lag schon 1997 bei 44 mm.

Generation MT – today everything changes

MAGURA's product manager Martin Schneider and development engineer Benny Strasser know what they're talking about. That's because on weekends they're usually pushing the products they develop during the week to their limits on downhill racetracks. "The MAGURA DNA of the Gustav M is 100% gravity, that's what we wanted to transfer to the MT7 and the whole product family", reports Benny Strasser. "You're only going to achieve the right gravity performance with 4 pistons. On top of that, reliability

and stability are top of our list," explains mechanical engineer Martin Schneider. The definitive return of MAGURA to the top class of mountain bike racing came in the form of the neon yellow MT7 Raceline (mimicking the visual look of the HS22 and Gustav M) used in the German 2014 Downhill Championship. Since then, proof of the new MT quality has come in the form of the numerous best-in-test awards in the specialist press. The MAGURA team even took the award "Innovation of the Year" for the MT7 Raceline.

The latest member of the MT family with its dazzling chrome brake caliper is the MT Trail Carbon. It is a perfect match to the important trail/all-mountain sector, coming between MT8 and MT7. The show stopper: the MT Trail Carbon has 4 front and 2 rear pistons – the optimum braking performance for demanding trails. The proven technologies of the MT7 and MT8 brakes extend throughout the range. Here, the successful MT8 is representative of all the 2 piston systems, such as the MT6, MT4 and MT2. While MT7 and MT5 represent the 4 piston systems. Each system comes with features to match its use and price range.

Over the last 20 years, MAGURA know-how from motorbike and mountain bike engineering has developed continuously from the HS22 via the Gustav M up to the MT7 while always remaining true to its neon yellow roots. Back in the day, it was Jürgen Beneke, Regina Stiefl and John Tomac who pushed back the limits of mountainbike sports. Today, it is riders such as Danny MacAskill, Johannes Fischbach, Brett Tippie, Harald Philipp and Fabio Wibmer who, through constant challenging of the status quo, push MAGURA beyond new limits.

er Magura Gustav M entstand Ende der 90er Jahre
wohl berühmteste aller Scheibenbremsen. Doch was
ich seither eigentlich getan? Wir haben Maguras
dären Wurfanker mit der neuen MT7 verglichen.



Benjamin Hahn

MT新世代- 今時今日大不同

MAGURA的產品經理Martin Schneider和開發工程師Benny Strasser知道自己在說什麼。

因為他們經常在週末，將週間研發出來的產品帶到下坡賽道上去操駕，把產品的性能發揮到淋漓盡致。

Benny Strasser表示：「Gustav M骨子裡蘊含著100%重型速降DNA的特質。我們想將這份獨特的DNA植入MT7，並將其概念運用於整個煞車家族的設計」。

機構工程師Martin Schneider指出：「唯有4活塞煞車能在高速下坡發揮理想的制動性能。除此之外，產品的可靠性和穩定性一直是我們的首要考量」。

瑪古拉決心重返登山車最高賽事殿堂，而霓虹黃MT7 Raceline扮演著十分關鍵的角色(經典重現HS22和Gustav M的搶眼視覺)，現身於2014德國下坡車全國錦標賽賽事中。

此後，新世代MT煞車系列的品質已在無數專業媒體評測中，獲得最佳測試產品獎的肯定。

MT7 Raceline甚至榮獲年度最佳產品創新獎。

披上銀光閃耀的外衣，MT家族再添新成員MT Trail Carbon碟煞。

設計概念來自MT8與MT7煞車，結合兩者的特性，能完美地應用於林道/全山地車種。令人驚豔的是：MT Trail Carbon採前4後2活塞設計 – 在各種嚴苛的地形都能發揮優越的制動性能。

此外，經MT7和MT8驗證的技術經驗，已全面應用於碟煞產品系列。其中，2活塞系統以MT8為首，往中高階至入門款發展，如：MT6、MT4及MT2。4活塞系統，以最高階MT7至中高階MT5為代表。

每套系統的技術特點皆依騎乘需求做設計，同時提供合理的價格點。過去這20年中，瑪古拉結合重型摩托車和登山車的技術經驗並持續研發創新，從HS22到Gustav M直至MT7，始終以霓虹黃色為根基。

當時的世界級車手Jürgen Beneke、Regina Stiefl和John Tomac一再挑戰越野登山車賽的極限。而如今，還有許多頂尖車手們，如：Danny MacAskill、Johannes Fischbach、Brett Tippie、Harald Philipp和Fabio Wibmer，透過不斷挑戰現狀，激發瑪古拉永不言倦的決心與企圖，將極限再推向高峰。

MountainBIKE 05/16

MOUNTAINBIKE

* since 6/2016 also a shimano shifter

PRODUCT

PRO

OVERVIEW

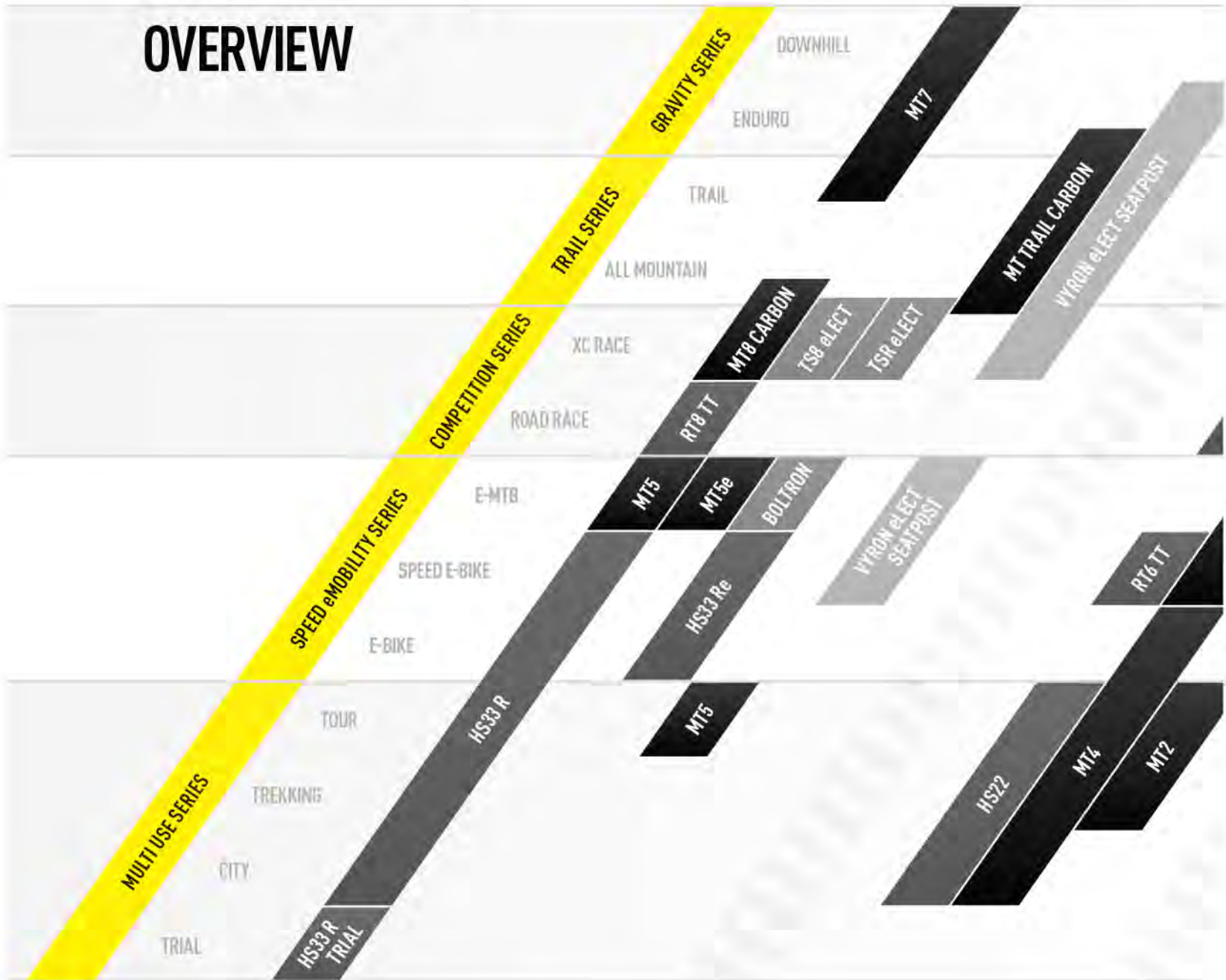

Welcome to MAGURA Product Worlds 2017

Here, you can see the MAGURA 2017 Product Worlds at a glance: Brakes, suspension forks, rear shocks, and dropper seatpost for city commuter, trekking, road and mountain bike. And special models for the emerging e-bike segment. The biggest innovations for 2017 are in MAGURA's core segment, MT disc brakes and HS rim brakes.

The MT Trail Carbon disc brake sets new benchmarks for trail and all-mountain bikers. 4 front pistons and 2 rear pistons deliver 100% braking performance even on the most demanding trails. The light MT8 has shed even more weight for the Olympics and the MT6 comes with a new fresh look with a dazzling chrome caliper. Dealers and racers alike will be happy with the HS11 tune-up for 2017: the assembly maintains its small foot-

print thanks to a split clamp, and the cable can now be simply shortened at the master piston end.

Via the overviews you can quickly and easily find the product you want. For a more detailed look at the many and varied uses, see the pages that follow. We follow the athletes and passionate bikers as they reveal their experiences and fun with MAGURA products. From the road to Rio, via the thrill of steep trails, carefree circumnavigation of the world on two-wheels up to the ultimate trust that a world star like Danny MacAskill has to have in his brakes. Our products make it possible for people across the globe to discover and push out their limits, on-road and off-road. Changing the game.

ADVANCED

BASIC



Photo: Nathan Hughes

瑪古拉2017年全產品線

在這裡，您可縱觀瑪古拉2017年全系列產品：有油壓煞車、避震前叉、後避震和伸縮座管，適用於城市休閒車、越野車、公路車和登山車。也特別將產品線拓展至新興電動自行車市場。2017年瑪古拉核心產品的創新，主要在MT碟煞及HS輪圈煞系列。

油壓碟煞MT Trail Carbon成為林道車和全山地車新標竿。即使在最為苛刻的地形上，前4後2活塞的設計，也能提供100%的制動性能。輕量化的MT8為了奧運會進行更完美的重量優化。MT6換上閃亮的鍍鉻卡鉗，以煥然一新的樣貌現身。

還有讓人眼睛為之一亮的2017年版HS11新裝上陣：現在可簡單地從煞把端剪管。

透過產品總覽，您可以快速、輕鬆地找到您想要的產品。更多詳細用途及資訊，請繼續往下翻頁。我們樂見瑪古拉產品勾起人們心中的單車熱情，盡情享受騎乘的樂趣。一路騎到里約熱內盧、奔馳陡峭道路的刺激快感、實踐單車環遊世界的夢想，甚至像世界級街攀巨星Danny MacAskill都將他們對瑪古拉的信任安裝在愛車上。讓我們的产品陪您將一切變得可能，無論是平坦或崎嶇的道路，都要陪您走遍世界，陪您挑戰超越自我極限。跟著瑪古拉一起，突破規限、開關新局吧！



Photo: Philip Ruopp

infinite, flowing and picture-postcard pretty – everyone has their ‘favorite trail’ ... Whether the Rockies, Alps, or the Swabian Jura, every mountain biker wants the same: fun on the trail. And only if you can always rely on your brakes to the point where you simply take them for granted can you just enjoy your ride and the mastery you have over your machine. All out braking for the extreme; controlled braking for the flow. Absolute reliability and stability, regardless of how hard, how steep or how long the downhill. Then, when you reach the bottom you look back up with a smile of achievement.

MAGURA MT disc brakes are constantly being improved until they can meet these high demands. Then to complete your enjoyment on the trail, all you need is the optimum seatpost. 無窮無盡、流動的水域、如詩如畫般美麗 - 每個人都有自己的“私房秘境”...無論在哪個群山間穿梭，落磯山脈、阿爾卑斯山還是施瓦本汝拉山，每位登山車友都想著：我要盡情奔馳山林，享受越野樂趣！因此，你需要安全可靠煞車系統，你知道施多少力道可以得到多少制動力、輕輕按壓就給你完全的回應。不用想也能感受到它會在那裏守候著你。無論是奔馳於亂石遍佈的山坡還是側身速降滑下陡峭的路段，你就是知道你的煞車永遠都會為你發揮作用。瑪古拉MT-碟煞持續精進改良，務求提供最佳品質與最高滿意。享受悠遊自得的騎乘樂趣，你會需要一支優秀的座管來圓滿。

The MAGURA VYRON eLECT gives you just that and you can quickly and easily match the saddle height to the situation. The trail nosedives, one press of a button, brief loading and the saddle is out of the way. The roller coaster switches up, your thumb intuitively finds the eLECT button and straightaway you can step on the pedals with full power to start the ascent. More control, more safety and more fun.

Over the past few months, numerous best-in-test awards and ratings from the specialist magazines and websites such as ‘awesome’ and ‘outstanding’ testify to the know-how and long years of experience of our engineers and the intelligent production methods used in our designs.

瑪古拉VYRON無線伸縮座管，讓你可輕鬆、快速地調整座墊到你想要的高度。當前輪離開陡坡邊緣，準備急速俯衝，只需按一下按鈕，便能控制座管下壓。當陡坡攀升，你的大拇指很容易就可按下eLECT遙控器的按鈕來升高坐墊，助您專心攻頂。回伸速度與下壓力之間取得最佳平衡，讓車手可專注在車況的操控，同時享受更多的騎乘樂趣和安全性。在過去的幾個月裡，本產品已多次獲得專業媒體和評測網站之最佳測試獎的正面評價，也肯定瑪古拉將長年累積的技術經驗及高科技工法注入於產品設計的理念。

TRAIL SERIES

Endlos, flowig und malerisch schön – jeder hat seinen „Lieblingstrail“ ... Ob man in den Rocky Mountains, in den Alpen oder auf der Schwäbischen Alb unterwegs ist – als Mountainbiker will man immer das Gleiche: Spaß auf dem Trail. Nur wer seinen Bremsen immer und uneingeschränkt vertraut, ohne darüber nachdenken zu müssen, kann in vollen Zügen genießen und die Kontrolle bewahren. Voller Biss für das Extreme, dosierbare Bremskraft für den Flow. Absolute Zuverlässigkeit und Standfestigkeit, egal wie hart, wie steil oder wie lang es bergab geht. Unten angekommen blickst du mit einem breiten Grinsen zurück.

MAGURA MT-Scheibenbremsen wurden immer weiter verbessert, bis sie diesen hohen Ansprüchen genügen. Zum Spaß auf dem Trail fehlt dann nur noch die optimale Sattelstütze – mit der MAGURA VYRON eLECT passt du die Sattelhöhe schnell und unkompliziert auf die Situation an. Der Trail kippt ab – ein Knopfdruck, kurze Belastung und schon ist der Sattel aus dem Weg. Die Achterbahn steigt an, dein Daumen findet intuitiv den eLECT-Knopf und schon kannst du mit voller Power nach oben treten. Mehr Kontrolle, mehr Sicherheit, mehr Spaß.

Zahlreiche Testsiege und Prädikate von Fachmagazinen und Websites wie „Super“ und „Hervorragend“ in den vergangenen Monaten bestätigen das Know-how und die jahrelange Erfahrung unserer Ingenieure und die intelligente Bauweise unserer Konstruktionen.

MAGURA Trail Series products: MT Trail Carbon, VYRON eLECT Seatpost



Photo: Markus Slavik

COMPETITION SERIES

Olympiasiegerin Sabine Spitz verlässt sich voll und ganz auf die MAGURA MT8. In der Vorbereitung auf ihre vierten Olympischen Spiele bestritt sie im Frühjahr das Cape Epic, das legendäre Etappenrennen in Südafrika über 650 Kilometer und 15.000 Höhenmeter durch Sand, Staub und Hitze, um sich und ihr Material zu testen. „Obwohl es extrem hart ist, macht das Rennen sehr viel Spaß. Die Trails sind unglaublich abwechslungsreich und verlangen volle Konzentration auf jedem Meter. Da ist man froh, wenn alles am Bike zuverlässig funktioniert“, meinte Sabine nach der Bewährungsprobe.

Ob Profi oder Tourenfahrer, alle wollen das Gleiche – maximale Performance bei möglichst wenig Gewicht. Egal, ob man bei den Olympischen Spielen oder beim Wochenend-Marathon antritt, oder eine Transalp meistern möchte. Die Competition-Serie wurde genau für diese Ansprüche entwickelt. Mit unseren High Tech-Materialien wie Carbotechnology SL ermöglichen wir Zuverlässigkeit bei geringstem Gewicht und bieten durch die Chromzange der MT6 auch ein optisches Highlight. Die MT8 funktionierte auch am achten Finaltag zuverlässig und präzise wie am ersten Tag beim Prolog. Sabine Spitz belegte mit ihrer Partnerin den 2. Platz. Olympia kann kommen, viel Erfolg!



Photo: Ralf Schäuble



Photo: Irmo Keizer

Photo: Irmo Keizer



MAGURA Competition Series products: MT8 Carbon, MT6, RT6 TT, TS8, TS8 eLECT, TS R eLECT, eLECT Upgrade Kit

Olympic champion Sabine Spitz relies completely on the MAGURA MT8. In preparation for her fourth Olympic games at the start of the year, she competed in the Cape Epic, the legendary stage race in South Africa covering 650 km and 15,000 m of altitude through sand, dust, and heat in order to test both herself and her machine. "Although the race is extremely hard, it's also a lot of fun. The trails are unbelievably varied and you need your full concentration every step of the way. So you're happy when everything on the bike works reliably," enthused Sabine after her 'test ride'.

Whether you are a professional or just a tour biker, we all want the same, maximum performance for minimum weight. Irrespective of whether you're taking part in the Olympic Games, a weekend marathon or want to master a trans-alp trail. The competition series was developed for just these demands. With our high tech materials such as Carbotoecture SL, we can achieve maximum reliability for the lowest possible weight while at the same time also offering a visual highlight in the form of the chrome caliper of the MT6. The MT8 was still functioning as reliably and precisely on the eighth and final day as on the first day during the prolog. Together with her partner, Sabine Spitz took 2nd place. Bring on the Olympics, lots of luck!

深獲奧運冠軍Sabine Spitz信賴的瑪古拉MT8油碟，今年攜手征服南非Cape Epic登山車多日賽，也為她生涯第四次踏上奧運賽場做暖身。這場比賽以豐富的賽事路線聞名，進行將近650公里，總爬升超過15000公尺的競賽，多變的環境因素，都考驗著選手的臨場反應以及戰駒是否能提供足夠的支持。Sabine Spitz在賽後表示“雖然比賽非常艱難，但其實也滿好玩的！因為這條路線實在太嚴酷多變了！尤其在險峻陡峭的岩石地形，每一步你都必須全神貫注，這時你就會感謝你可靠的煞車為你發揮了作用！”無論你是專業的車手還是愛好旅行的車友，我們都希望帶給您同樣的產品感受 - 超輕量與超性能。無論你是否參加奧運或一場週末的馬拉松競賽，抑或只想恣意穿梭於群山林道間。競速系列正是為了滿足這些需求而生。其輕巧卻堅固耐用的產品特性，來自獨家Carbotoecture SL高科技碳纖維複合材料的運用。本季也特別為MT6卡鉗換上吸睛的閃耀銀外衣。而最高階碟煞MT8至始至終都扮演著精準可靠的角色，陪伴Sabine Spitz順利摘下銀牌！全力以赴前進奧運，祝她好運！



Photo: Michal Cerveny

Downhill is the formula 1 of mountain bike sports, now more than ever. On racing tracks around the world, thousandths of a second are now fought for with maximum commitment. To say that the pressures on the rider and machine are extreme is an understatement. In the Radon MAGURA Factory Downhill Team, our products are put through an absolute hardness test across the whole globe. Mud, rain and cold in Canada and Great Britain. Dust, sandpaper grade sand and heat in Australia. The steepest and most abrasive downhill routes in the European Alps. Here, any weakness in either the rider or hardware is punished and the tracks are unforgiving and merciless.

The Radon Team with its four-time Swiss Champion Nick Beer and the German downhill champion Johannes Fischbach rely on the MT7. It is not just in the City-Downhill in Chile, which Fischbach won, that the margin between severe injury and the best time is paper thin; there is no room for compromise or more than a split second to think and decide.

In downhill sport, the Cube Global Squad put the MT7 through its paces nearly every weekend at race meetings. Global stars such as Cédric Gracia, Brian Lopes and Danny MacAskill rely on the performance of the MAGURA stopper. When Danny, as part of his Drop and Roll Tour, wants to fall from five meters onto a point no bigger than a dollar bill, there is no room for tolerance. Each brake application must count.

And MT7 4 piston technology is rock-steady dependable. Our engineers seek out and exploit the feedback of top level athletes. The exchange of information and feedback with and from the world's top riders is important and results in decisive new solutions for our brakes. At the limit where seconds are the difference between success and failure, none of our MAGURA riders needs to waste time worrying about braking performance. If you brake at the right time, you win.

GRAVITY SERIES

世界盃下坡賽場稱登山車界的「F1」，近年賽事規模更勝以往。頂尖選手們衝鋒陷陣、相互較勁，在千分之幾秒的差距間定出勝負。除了面對心理壓力，也不能低估腳下戰駒配備的重要性。就如瑪古拉贊助的下坡車隊Radon MAGURA Factory，配備的瑪古拉產品一律經過各種魔鬼地形的試煉，甚至橫跨南、北半球進行海外移地測試。最終操駕於阿爾卑斯山崎嶇蜿蜒的粗岩礫石，還有許多驚險的下坡路段，都無情的考驗車手與配備的耐力極限。

其中Radon車隊下坡賽選手Nick Beer，已四度衛冕瑞士下坡賽國家冠軍寶座。另一位選手 Johannes Fischbach則奪得下坡賽德國國家冠軍頭銜，而全程協助兩位拿下好成績的正是MT7油壓碟煞。以回饋世界頂尖車手的信任為使命，MT7再度陪伴Johannes挑戰難度甚高的城市下坡賽智利站，在住宅比鄰、陡峭狹窄的賽道上急速俯衝，幾乎沒有失誤的餘地，最終不但安全完賽更贏得好成績。

Cube Global Squad下坡車隊在每個周末的訓練中，都以激烈的操駕來證明MT7能夠持續提供精準的制動力道。瑪古拉煞車的性能表現，獲得眾明星車手們，如：傳奇下坡車手Cédric Gracia，世界冠軍車手Brian Lopes和街攀大師Danny MacAskill一致的信賴。當Danny和他的團隊Drop and Roll Tour進行巡演時，每個騰躍後的落點差距都錙銖必較，每次制動都必須精準到位。

MT7的4活塞技術能穩定提供可靠的制動表現。歸功於瑪古拉工程師善用頂尖運動員的反饋訊息，進行產品的改良並進一步推出創新的解決方案。在成功與失敗一線之隔的比賽中，瑪古拉車手或任何人都都不需要分神擔心制動性能表現。只要抓準煞車時機，你就是這場競賽的霸主！



Photo: Fabian Repp



Photo: Irmo Keizer



Photo: Sebas Romero

MAGURA Gravity Series products: MT7, MT5



Photo: Ilimo Keizer

SPEED SERIES eMOBILITY



Bikes and especially e-bikes have an important role to play in today's mobility. E-bikes are the fastest growing segment. Developing the right brakes for mountain and city bikes and fast s-pedelecs is right at the core of MAGURA's know-how. Many years of experience in the field of both motorbikes and mountain bikes come together in the special brake systems for e-bikes and s-pedelecs. The basis for the brakes is the mountain bike proven MT series. The braking performance and handling is the same as for state of the art mountainbike disc brakes. For e-bikes and s-pedelecs, MAGURA extends the MT system with motorbike style brake levers. The longer ball ended levers enable a safer two-finger grip. In addition, all MT and HS e-models with a switch in the brake lever activate the back light when braking.

The MAGURA MT and HS e-models are also suitable for e-bike motor systems that have an integrated recuperation function. Alongside the special MT and HS e-models, it is the operation and performance of the MT5 and the new HS11 which make them first choice for many manufacturers of sporty e-trekking and e-mountain bikes. As a family company now in its fourth generation, MAGURA sees it as part of its responsibility to drive forward the new mobility trends with its own know-how.



自行車發展至今，除了運動及休閒用途外，更在短程交通運輸上扮演重要角色。近年尤以電動自行車發展最為快速。

瑪古拉將核心的關鍵技術火力全開，結合長年累積於重型摩托車及登山車領域的技術經驗，致力研發適用各電動車款的制動系統。設計風格，以煞車性能及操控性都經登山車驗證的MT碟煞為基礎。提供圓球拉柄規格，概念延伸自摩托車領域，以符合電動車及電動車的安性規範。

此外，所有MT和HS的電動煞車版本，皆有提供控制煞車燈的功能。也適用於具有再生式電力煞車的馬達系統。

擁有絕佳操控性與制動表現的MT5和新款HS11，其電動煞車版本表現突出，成為成車廠組裝電動旅行車及電動登山車的首選。

瑪古拉期望透過傳承四代的智慧，成為推動兩輪電動車產業大潮的重要力量。





Photos: Philip Ruopp

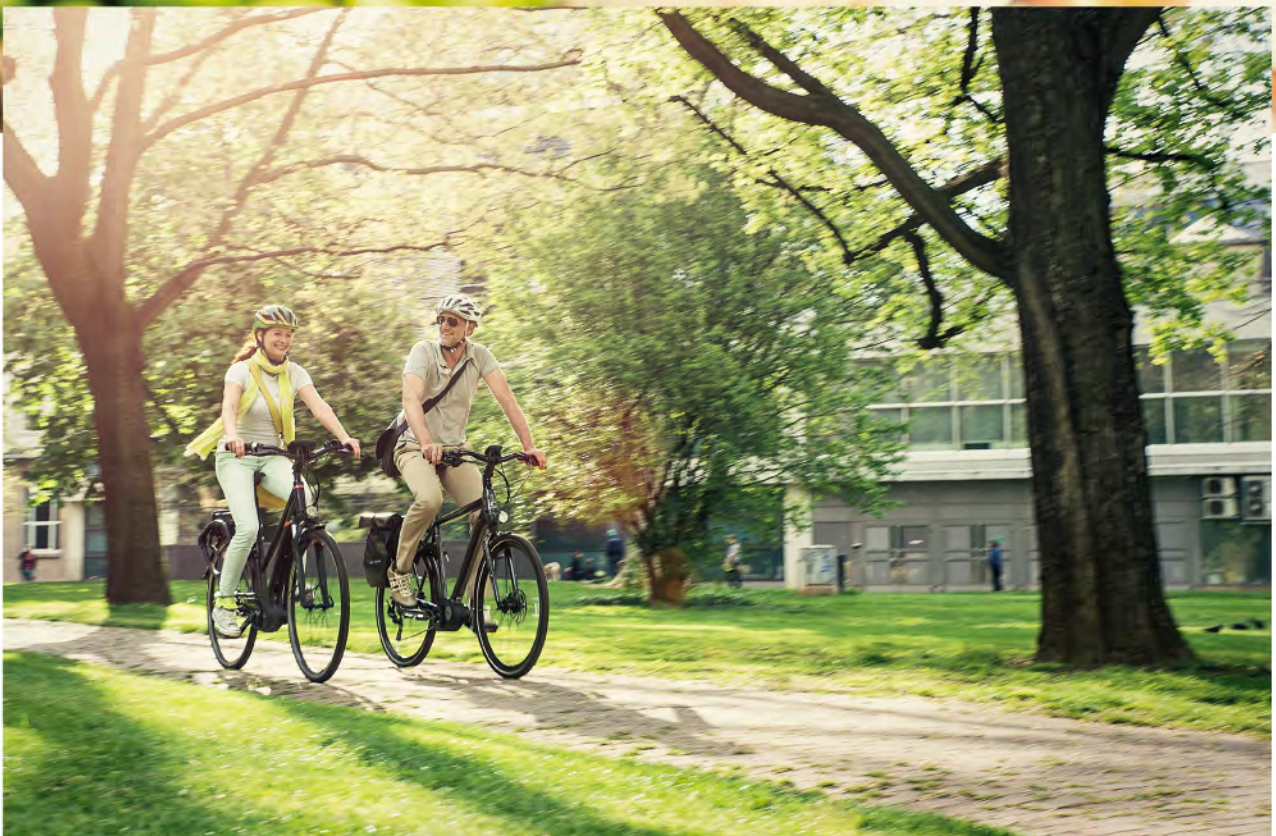



MULTI USE SERIES

What makes a legend immortal? You keep it up to date. When the HS series was born, it was a game changer; it paved the way for bicycle hydraulic brake systems. As trials star Hans 'No Way' Rey rode MAGURA at the start of the 1990s, all other trials fans switched over to the hydraulic rim stopper. Just as the bike has changed with the times, the riders change too, and Danny MacAskill, whose inspiration was Hans Rey, now also rides MAGURA.

In 2017, it will be precisely 30 years since the HS made its market debut. And now MAGURA HS brakes are fitted to more bikes than ever before.

For commuters and touring cyclists, globetrotters and everyday riders, MAGURA HydroStop brakes remain first choice. The low-maintenance requirement and reliability of our rim brakes remains unchanged. With the HS22 we successfully closed the gap in the market between the entry-level HS11 model and our HS33 R performance brake. Now, the HS11 has been completely revised, incorporating features from its big sister model, the HS33 R, while offering an optimum price-performance ratio and it is already fitted on many award-winning city and trekking bikes.

The legendary brakes of the HS family live on and in a unique combination given the fact that, right up until today, the same spare parts and accessories are still available. Not only have all the functions kept up with the times; anybody who fitted an HS brake to their bike twenty years ago knows precisely how to use and service it.

And talking about maintenance: Even today some riders have never changed the Royal Blood that flows in the veins of their brake systems. One more plus point for the MAGURA approach of making the bike carefree and ready for everyday life.

如何在不斷變化的時代中奠定經典不朽的傳奇？你不能只是墨守成規，持續創新與突破才是重要的關鍵。當年HS輪圈煞的誕生，一舉改寫既有的遊戲規則 - 為自行車液壓制動系統鋪平了道路。極限登山車教父 Hans 'No Way' Rey，在1990年代起開始配備瑪古拉煞車，成功帶動車迷改用液壓輪圈煞車的風氣。就像自行車的發展日新月異，前輩大師啟發後輩大師的例子也屢見不鮮，好比當今享負盛名的街攀大師 Danny MacAskill，就深受前輩 Hans Rey 的影響，進而成為瑪古拉煞車的愛好者。2017年，將為HS輪圈煞車迎來30周年的紀念年。而如今的瑪古拉HS煞車也能適用在更多元的車種上。

對於單車已成為生活日常或愛好單車旅行的車友來說，瑪古拉液壓制動系統依然是他們的第一首選。幾乎不需保養和穩定可靠的特性更是始終如一。

隨著HS22的誕生，我們成功推出介於入門款HS11跟講求制動表現的HS33 R之間的中階煞車。新裝上陣的HS11，結合其姊妹款式HS33 R的特點，提供更高的性價比，如今也能在多款獲獎的城市車和旅行車上看見它的身影。經典不敗，不管在哪个時代都大器得體的HS輪圈煞家族，彰顯著與時俱進的能量與視野，雖擁有創新的動能卻也保有自己的堅定靈魂，將原來的零配件沿用至今，因此，就算是20年前的HS煞車款式，你也知道該如何進行維修保養。

說到保養：直到今天，有些車友可能從來沒更換過煞車系統內的傳動媒介：皇家血統礦物油。這是瑪古拉另一個貼心之處，致力讓您無後顧之憂的享受每一趟愜意的單車之旅。

MAGURA TECHNOLOGY

MT TRAIL CARBON

Changing the game – for 100% trail performance. With the 2+4=3 MAGURA Logic, MAGURA has transferred a new concept to the trail. Professionals such as bike alpinist Harald Philipp, who rides on the limit, both inspired and tested the MAGURA MT Trail Carbon. For many such as Brett Tippie, Tibor Simai and Cédric Gracia there is a new favorite brake – MT Trail Carbon.

The new MT Trail Carbon with 4 front brake pistons and 2 rear brake pistons brings the best of both worlds to trail and enduro riding: absolute safe stopping thanks to the high front wheel braking force and outstanding modulation and control at the rear wheel. And, on top of that, for practically identical performance, there is a weight reduction in comparison with conventional downhill brakes.

改變遊戲規則 - 100%的攀爬性能表現。

瑪古拉新邏輯2+4=3，瑪古拉將新概念帶進攀爬車賽道。

如專攻高山路徑的職業攀爬車好手Harald Philipp，挑戰騎乘極限，對瑪古拉MT Trail Carbon來說既是啟發也是測試。

更多的好手如Brett Tippie, Tibor Simai 和 Cédric Gracia他們的新寵都是-MT Trail Carbon碟煞。

新的MT Trail Carbon前輪搭配4制動活塞，和後輪搭配2制動活塞，為世上的訓練用車及耐力車帶來兩全其美的解決方案：絕對安全的制動，得益於前輪的高煞車力道，搭配後輪出色操控，除了獨樹一格的制動及操控表現，與其他類似等級的下坡車煞車比較，重量上的減輕更是令人驚豔。

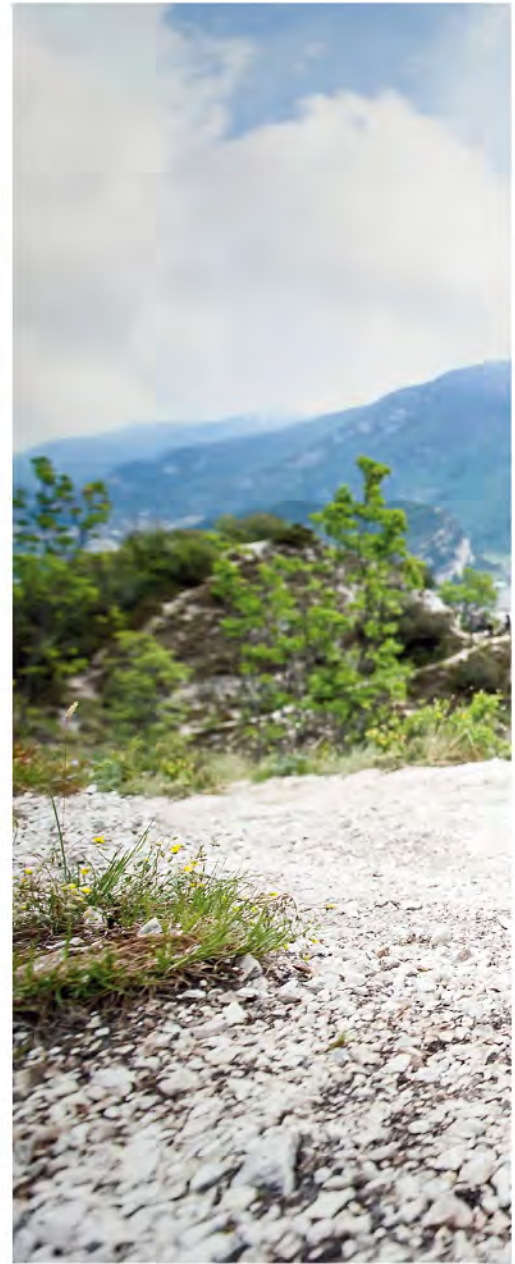



MAGURA TECHNOLOGY

eLECT CONNECTIVITY

瑪古拉 高科技

eLECT 智能連接技術

eLECT CONNECTIVITY

The first wireless connected bike components.

eLECT智能連接

市場第一套自行車用無線感應套件組



TS R eLECT
Rearshock
TS R eLECT
智能化後避震



eLECT
Remote
eLECT
無線遙控器



VYRON
eLECT Seatpost
eLECT無線伸縮座管



eLECT
Coach
eLECT
教練顯示器

TS8
eLECT
Fork
TS8
eLECT
智能化
避震前叉



eLECT – stress free connections

With its innovative eLECT-technology, MAGURA brought the first wireless system for suspension systems and remote dropper seatposts to the market. No more stress with time consuming cable routing, just a touch of the button control and adjustments can be made in seconds. Using the eLECT Remote mounted on the handlebar, you can quickly and safely adjust the VYRON seatpost to the height you want. A 3D acceleration sensor, which reacts to changes in microseconds, controls the lockout of the suspension forks and rear shock automatically. So you can concentrate on the essential and enjoy the trail.

Similarly, if you want to retain control of the bike suspension elements, you can easily manage this via the eLECT Remote. Upgrades are also possible: for anybody who wants to free their bike from cabling, an eLECT upgrade kit for MAGURA suspension forks has been available since 2010. More fun and safety when biking and less stress fitting and adjusting. This is always the aim when MAGURA sets out on new development paths.

eLECT - 毫無壓力的連結

憑藉其創新的e-LECT智能連接技術，瑪古拉發表市場上第一組無線遙控前避震器及無線遙控伸縮座管系統。再也沒有耗時傷神的佈線壓力，只需輕輕一觸按鈕，幾秒鐘內輕鬆完成調整。

將e-LECT智能遙控器安裝在車把上，您可以快速，安全地調整VYRON座管到你想要的高度。3D加速度傳感器，其反應的變化在萬分之一秒內，自動控制鎖死避震前叉和後避震。接下來，你可以專注在車況的操控及享受攀爬的樂趣。同樣，如果要恢復避震系統的手動操控，輕鬆的透過e-LECT智能遙控器即可完成。

升級也是可行的：想要擺脫走線的束縛，瑪古拉避震前叉的智能升級套件適用於所有2010年之後的系統。

更多的騎乘樂趣和安全，更少的壓力和調整。這始終是瑪古拉研發新產品的終極目標。



MAGURA ORIGINAL SPARE PARTS

FOR THE BEST BRAKING PERFORMANCE

The supply of all the important and wear parts from one supplier guarantees maximum performance and safety exactly where they're needed. This is why MAGURA's Original Spare Parts range offers a wide selection of spare and upgrade parts that undergo constant quality control and guarantee the maximum functionality of MAGURA products. All brake calipers and brake levers come with a five year no-leak warranty when used with 100% MAGURA components. Individual set-ups are possible to meet any requirement thanks to brake discs in all the current sizes and brake pads for every application, from comfort through to performance and racing. Heavier e-bikes, in particular, need more braking power, which is why the spare parts range also offers different brake shoe options for the MT and HS brakes.

The environment is a priority for MAGURA so all of its hydraulic brake systems are filled with Royal Blood mineral oil. Royal Blood is an easy to handle mineral oil. Any spilled Royal Blood will not harm the paintwork or cause any material corrosion. The major advantage is that Royal Blood is not hygroscopic so it does not absorb air moisture, does not age and hence does not require periodic changing like DOT brake fluid.

Please check the wear of your brake discs and pads regularly. Worn brake pads can be changed in seconds thanks to magnetiXchange. MAGURA Original Spare Parts, so that you can always rely on your brakes.

5 YEARS WARRANTY

MAGURA gives five years leak proof warranty for all MAGURA brake calipers and brake pistons if they were used with MAGURA Original Spare Parts.

QUALITY AND FUNCTION

All MAGURA Original Spare Parts go through continuous quality controls. They have the same quality level as the products used for production.

BRAKE PADS AND ROTORS

The best braking performance is guaranteed if our original MAGURA brake pads and rotors are used.

瑪古拉正廠零件 為最佳制動力而生

重要零組件和損耗品來自同一供應商，能保證提供最高性能和安全性。這就是為什麼瑪古拉原裝配件系列，提供廣泛的備品選擇、升級配件，出廠前還需通過嚴格的品質認證，確保發揮瑪古拉產品的最大功能。在100%使用瑪古拉正廠零組件的前提下，所有制動卡鉗和煞車把手提供五年防漏保固。多虧靈活多樣的碟盤及來令片設計，使得消費者自己在家動手調校變得容易。無論是舒適度到高性能及競賽，任何搭配都能被滿足，特別是較重的電動自行車，需要更強大的制動力，因此更特別為MT和HS系列提供不同的來令片選擇。

環境保護一直是瑪古拉的優先考量，所有的液壓制動系統都使用皇家血統礦物油。皇家血統礦物油是相當容易使用的礦物油。溢出的皇家血統礦物油不會傷害車漆，或導致任何材料腐蝕。皇家血統礦物油的主要優點是不吸濕，因此不會吸收空氣中的濕氣、不老化，因此不像DOT油品需要定期更換。

請定期檢查您的碟盤和來令片的磨損。磨損的來令片可以於幾秒重內更換完成，歸功於magnetiXchange貼心設計。只要使用瑪古拉原裝配件，你可以永遠信賴你的煞車。



Photos: Philip Ruoppi





5年防漏保固

在100%使用瑪古拉正廠零配件的前提下，
所有制動卡鉗和煞車把手提供五年防漏保固。

品質及功能保證

所有瑪古拉正廠零配件系列，
出廠前皆必須通過嚴格的品質認證，
確保發揮瑪古拉產品的最大功能。

來令片及碟盤

使用瑪古拉正廠來令片及碟盤，
能保證煞車發揮最佳制動性能。

DISC BRAKES MT TECHNOLOGY

碟煞系列 MT獨家技術



TRIPLE ARCH DESIGN
Ultimate brake caliper rigidity
三拱橋設計
提供卡鉗絕佳剛性



MAGNETIXCHANGE
Easy brake pad replacement
磁吸式卡鉗活塞
大幅簡化來令片更換作業



BANJO FITTING
Rotatable hose routing
可調式油管
可配合車架調整油管走線位置



EASY BLEED TECHNOLOGY
Quick and easy bleeding
易注油技術
灌油作業超簡單



BITE ADJUST TECHNOLOGY
Tool-less bite adjust
煞車靈敏度微調技術
免工具進行靈敏度調整

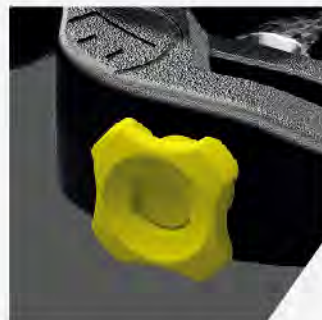

TOOL-LESS REACH ADJUSTMENT
Tool-less reach adjust
免工具握距調整技術
免工具進行握距調整

DESIGNED AND ENGINEERED IN GERMANY
德國研發設計

5 YEARS LEAK PROOF WARRANTY
5年防漏油保固

FILLED WITH ROYAL BLOOD
使用皇家血統礦物油

MAGURA PERFORMANCE
Deceleration
瑪古拉超性能煞車
減速性能

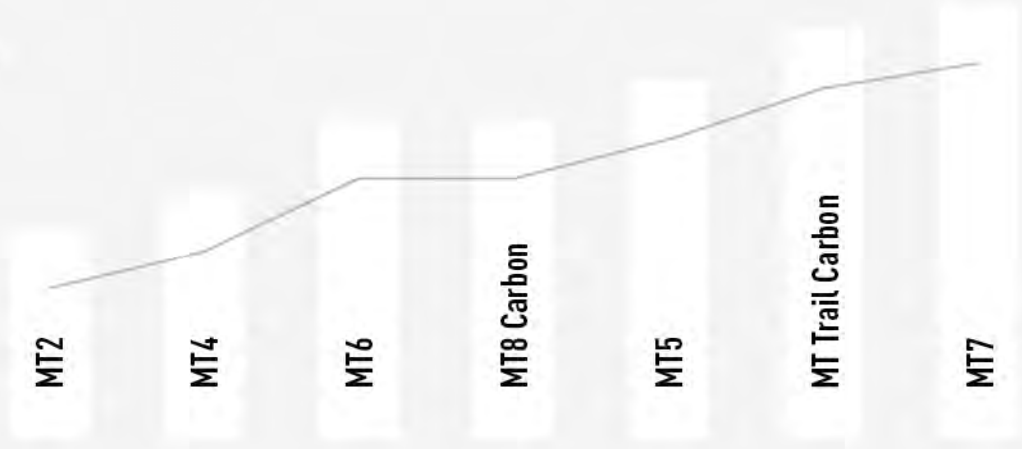



Photo: Philip Ruopp

NEW



MT TRAIL CARBON

MAGURA's new definition of trail braking performance - 4 front pistons for maximum braking power, 2 rear pistons for perfect modulation. All for a weight of just 330 grams (average value).

全新定義! 提供林道越野卓越的煞車性能及操控表現 - 前輪四活塞卡鉗, 提供絕佳的制動力道; 搭配後輪對向二活塞卡鉗, 提供完美的操控性。總重量僅330克(平均值)。

Weight (g) 重量	330* (average value 平均值)
Master 本體	Carbotecture SL 高科技碳纖維複合材質
Lever Blade 拉柄	Carbolay 全自動定位的不間斷碳纖維粗紗成型
Reach Adjust 握距調整	Tool allen3 3號內六角扳手
Bite Adjust 靈敏度調整	-
Pistons 活塞	4/2
RRP (€) 建議售價(歐元)	579,90 (Set套)**
Order No. 產品編號	2701 213

TRAIL SERIES

100% TRAIL PERFORMANCE
發揮100%林道越野煞車操控性能

LIGHTWEIGHT 輕量化

EYECATCHER 超吸睛

* incl. 160 mm rotor and screws, without adapter * 包含160 mm碟盤及螺絲, 不包含轉接座。
** without rotor/adapter ** 不包含碟盤/轉接座

MT8 CARBON

First choice for cross country, super light thanks to Carbolay lever but still with high braking force. Always ready, when you need to slow down fast. Sabine Spitz, the Olympic champion also relies on the MT8.

輕度越野車的最佳首選!以獨家Carbolay成型工法，打造極輕量化卻能發揮精準煞車力道的拉柄結構。確保一切都在你的掌控之中。MT8碟煞，更以其優異的性能贏得奧運常勝軍Sabine Spitz的信任!

Weight (g)重量	299*
Master 本體	Carbotecture SL 高科技碳纖維複合材質
Lever Blade 拉柄	Carbolay 全自動定位的不間斷碳纖粗紗成型
Reach Adjust 握距調整	Tool allen3 3號內六角扳手
Bite Adjust 靈敏度調整	-
Pistons 活塞	2
RRP (€) 建議售價(歐元)	279,90**
Order No. 產品編號	2701 210

MT7

The legitimate heir to the Gustav M, with new high-tech and motorbike attributes. Optimum heat transfer, clearly defined pressure point, maximum power. Developed for gravity and high-speed riders.

Gustav M的正宗傳人，結合獨家高科技工法及重機技術打造。擁有絕佳的散熱性能、精準的煞車作動及強大的制動力道。是您征服瞬間急轉及陡峭下坡的最佳利器。

Weight (g)重量	375*
Master 本體	Carbotecture SL 高科技碳纖維複合材質
Lever Blade 拉柄	Hollow Aluminium 鋁合金中空拉柄
Reach Adjust 握距調整	tool-less 免工具
Bite Adjust 靈敏度調整	tool-less 免工具
Pistons 活塞	4
RRP (€) 建議售價(歐元)	219,90**
Order No. 產品編號	2701 211

FACELIFT



COMPETITION SERIES

RIDE TO WIN 絕佳的競速武器

LIGHTWEIGHT PERFORMANCE 高性能輕量化煞車

ULTIMATE IN ENGINEERING 先進的技術工法



FACELIFT



GRAVITY SERIES

AWARD-WINNING BRAKING PERFORMANCE
榮獲最佳測試產品獎

ADAPTABLE ERGONOMICS 符合人體工學

WEIGHT RATIO PERFORMANCE 最佳重量性能比





Photo: Philip Ruopp

FACELIFT 全新換裝



MT6

For everyday use and the first sorties into competition, reliable performance in all situations. The MT6 with its Carbotecture SL brake lever and chrome polished aluminum caliper cuts a dashing figure at race meets and on tours.

無論是日常使用或出征賽事，在任何情況下，都能展現十足可靠的煞車性能。MT6換上閃亮的鍍鉻銀卡鉗搭配Carbotecture SL高科技碳纖維複合材料打造而成的煞車本體，讓您一出場，馬上成為眾所矚目的焦點。

Weight (g) 重量	320*
Master 本體	Carbotecture SL 高科技碳纖維複合材質
Lever Blade 拉柄	Hollow Aluminium 鋁合金中空拉柄
Reach Adjust 握距調整	tool-less 免工具
Bite Adjust 靈敏度調整	-
Pistons 活塞	2
RRP (€) 建議售價(歐元)	179,90**
Order No. 產品編號	2 701 212

COMPETITION SERIES

COMPETITION USE 賽事上的好夥伴

ELEGANT DESIGN/FINISH 精緻吸睛的外型

LIGHTWEIGHT TECHNOLOGY 輕量化技術打造

* incl. 160 mm rotor and screws, without adapter *包含160 mm碟盤及螺絲，不包含轉接座。
** without rotor/adapter **不包含碟盤/轉接座

MT5

The full gravity brake power of 4 pistons for an affordable entry price. All the DNA of the MT7 is included in our MT5 model for downhill and enduro riding. Reliable, strong and light on the scales.

四活塞卡鉗的經濟入門款。

擁有與MT7相同的重型速降DNA的特質，是您征服極速下坡與飛越高低落差障礙的最佳夥伴。

Weight (g) 重量	380*
Master 本體	Carbotecture® 高科技纖維複合材質
Lever Blade 拉柄	Aluminium 鋁合金
Reach Adjust 握距調整	Tool T25 T25星形螺絲起子
Bite Adjust 靈敏度調整	-
Pistons 活塞	4
RRP (€) 建議售價(歐元)	109,90**
Order No. 產品編號	2700 477

GRAVITY SERIES

GENES OF THE MT7 內建MT7速降魂
ENTRY-LEVEL 4-PISTON BRAKING POWER 四活塞卡鉗入門款
HIGH-QUALITY MATERIALS 高品質材料打造



MT4

The perfect all-rounder for mountain bikers who value stability and brake power, without having to compromise on weight. The Carbotecture® master keeps the entire weight below 355 grams.

登山車手夢寐以求的全能產品，擁有穩定可靠的煞車力道及絕不妥協的輕量化特性。

獨家Carbotecture®纖維複合材質打造的輕量化煞把，使煞車系統的整體重量低於355克。

Weight (g) 重量	350*
Master 本體	Carbotecture® 高科技纖維複合材質
Lever Blade 拉柄	Aluminium 鋁合金
Reach Adjust 握距調整	Tool T25 T25星形螺絲起子
Bite Adjust 靈敏度調整	-
Pistons 活塞	2
RRP (€) 建議售價(歐元)	89,90**
Order No. 產品編號	2700 476

MULTI USE SERIES

PERFECT ALL-ROUNDER 完美演繹全能風采
VERY GOOD PRICE/PERFORMANCE RATIO 最佳性價比
INNOVATIVE TECHNOLOGY 創新科技



MT2

The entry level of the MAGURA MT world. All of the high-tech features of German engineering skill such as improved lever geometry for two-finger braking. Safe stopping whether touring or commuting.

瑪古拉MT碟煞系統中的超值入門款!

設計概念處處可見德式工藝精神，如經改良的2指拉柄結構，能提供更精確、安全的煞車力道。

Weight (g) 重量	365*
Master 本體	Carbotecture® 高科技纖維複合材質
Lever Blade 拉柄	Carbotecture® 高科技纖維複合材質
Reach Adjust 握距調整	Tool T25 T25星形螺絲起子
Bite Adjust 靈敏度調整	-
Pistons 活塞	2
RRP (€) 建議售價(歐元)	54,90**
Order No. 產品編號	2701 209

MULTI USE SERIES

JOIN THE MAGURA MT FAMILY 瑪古拉碟煞家族入門款
ONE-PIECE BRAKE CALLIPER AND CARBOTECTURE® 一體成形的煞車卡鉗
COMFORTABLE ERGONOMICS 符合人體工學設計



* incl. 160 mm rotor and screws, without adapter *包含160 mm碟盤及螺絲，不包含轉接座。
 ** without rotor/adapter **不包含碟盤/轉接座



Photo: Philip Ruopp



Photo: Philip Ruopp



Photo: Denis Katzer

RIM BRAKES HS TECHNOLOGY

輪圈煞車系列 HS 獨家技術



EASY PAD REPLACEMENT
Easy brake pad replacement

來令片易更換設計
大幅簡化來令片更換作業



BRAKE BOOSTER
Brake booster for optimized pressure point

煞車補強片
避免煞車力道大於車架受力而產生變形



EASY BLEED
Quick and easy bleeding

易注油技術
灌油作業超簡單



FIRM TECH
Optimized braking power and reduced weight because the brake is mounted directly

完全整合技術
本煞車可直接安裝於前叉上，不僅減輕重量也帶來更強大的煞車力道。



HS EASY MOUNT
Easy mount and adjustment

HS 簡易安裝
提供更簡易的安裝及調整步驟



EVO2
Flexible adaptation to all systems

EVO 固定座
能更彈性的適應所有系統

RT TECHNOLOGY RT 系列 獨家技術



LIGHT-ACTION BRAKING
Ball bearings for light-action braking

輕鬆發揮制動效能
滾珠軸承設計，輕鬆發揮制動效能

 **DESIGNED AND ENGINEERED IN GERMANY**
德國研發設計



AERODYNAMIC DESIGN
Aerodynamic surface for low drag

空氣力學設計
符合空氣力學的外型設計，能降低風阻

5 YEARS LEAK PROOF WARRANTY
5年防漏油保固

 **FILLED WITH ROYAL BLOOD**
使用皇家血統礦物油



Photo: Philipp Kneip

NEW



HS11

The latest in the family and it is just as reliable as its big sisters. With a revised master piston for high everyday braking force. Very comfortable thanks to the ergonomic lever design.

在HS家族裡排行最小的HS11，不讓其姊妹追美於前，憑著可靠的性能表現嶄露頭角。經改良的煞把設計，能提供更細膩的煞車力道。符合人體工學的拉柄設計，提供更舒適的手感。

Weight (g) 重量	425
Master 本體	Carbotecture® 高科技纖維複合材質
Lever Blade 拉柄	Carbotecture® 高科技纖維複合材質
Reach Adjust 握距調整	-
Bite Adjust 煞車塊間隙調整	Tool T25 T25星形螺絲起子
Lever Blade 煞車拉柄	3-Finger 3-指
Mounting 煞車固定座	Cantilever EVO2, EVO2固定座 Easy Mount 簡易安裝固定座
RRP (€) 建議售價(歐元)	69,90
Order No. 產品編號	2 701 214 ^a

MULTI USE SERIES



THE CAREFREE BRAKE 無須費心照顧的煞車系統
ERGONOMIC AND STRONG 符合人體工學堅固耐用
PRECISE CONTROL 提供精準的操控性

HS22

Fitted to many award winning bicycles because commuter and trekking riders value safety and low-maintenance features. The Royal Blood can remain in the brake tubing forever.

穩定可靠且幾乎不需保養的特性，深獲單車通勤族及喜愛單車旅行的車友們青睞，如今已能在多款獲獎的車種上看見它的身影。以皇家血統礦物油作為傳動媒介，封閉式系統讓您完全不須費心保養。

Weight (g) 重量	440
Master 本體	Carbotecture® 高科技纖維複合材質
Lever Blade 拉柄	Carbotecture® 高科技纖維複合材質
Reach Adjust 握距調整	tool-less免工具
Bite Adjust 煞車塊間隙調整	TPA 調整鈕
Lever Blade 煞車拉柄	3-Finger 3-指
Mounting 煞車固定座	Cantilever EVO2, EVO2固定座 Easy Mount 簡易安裝固定座
RRP (€) 建議售價(歐元)	89,90
Order No. 產品編號	2 700 845 ^b



MULTI USE SERIES

PROVEN ERGONOMICS 經驗證的人體工學設計

ELEGANT DESIGN AND HIGH-QUALITY MATERIALS 雅致設計與高質感設計用料

THE LATEST MODEL OF CAREFREE BRAKES 輪圈煞系列中最新產品

HS33 R

Our unbeatable classic. The MAGURA top model in the carefree family, scores thanks to its reliability and offers increased braking force with low weight due to the Carbotecture® brake master.

經典不敗款!瑪古拉輪圈煞的最高階款。超高評價來自穩定可靠的特性，煞把本體使用 Carbotecture®高科技纖維複合材質，輕量化的同時也提高剎車制動力。

Weight (g) 重量	465
Master 本體	Carbotecture® 高科技纖維複合材質
Lever Blade 拉柄	Aluminium 鋁合金
Reach Adjust 握距調整	Tool T25 T25星形螺絲起子
Bite Adjust 煞車塊間隙調整	TPA 調整鈕
Lever Blade 煞車拉柄	2-Finger; opt.: 4-Finger, 2-指選配:4-指 3-Finger ball-end 3-指加圓頭
Mounting 煞車固定座	Cantilever EVO2 EVO2固定座
RRP (€) 建議售價(歐元)	109,90
Order No. 產品編號	2 700 245 ^c



MULTI USE SERIES

SPORTY DESIGN 運動風設計

THE FLAGSHIP OF CAREFREE BRAKES 輪圈煞中的旗艦款

HUGE BRAKING POWER FOR RIM BRAKES 擁有最強勁的煞車力道

^b 2 700 845: 3-Finger, EVO2 / 2 700 846: 3-Finger, Easy Mount 黑色, 2指

^c 2 700 245: silver, 2-Finger 銀色, 2指 / 2 700 246: black 黑色, 2指, 2-Finger / 2 700 247: black, 4-Finger 黑色, 4指



HS33 R TRIAL

Our rim brake classic for trial pros. The brake levers with their fully removable handle bar clamps ensure super-fast attachment and removal. The HS33 R Trial impresses thanks to its the elegant 2-finger lever.

專為攀岩車玩家們設計的經典輪圈煞。
煞把採分離式固定環設計，可快速拆卸及安裝。
HS33R Trial的2指拉柄設計，勾勒出簡潔俐落的視覺線條。

Weight (g) 重量	320
Master 本體	Carbotecture® 高科技纖維複合材質
Lever Blade 拉柄	Aluminium 鋁合金
Reach Adjust 握距調整	Tool T25 T25星形螺絲起子
Bite Adjust 煞車塊間隙調整	TPA 調整鈕
Lever Blade 煞車拉柄	4-Finger; opt.: 2-Finger, 4-指選配:2-指, 3-Finger ball-end 3-指加圓頭
Mounting 煞車固定座	IDM 攀岩車固定座
RRP (€) 建議售價(歐元)	109,90
Order No. 產品編號	2700 248



MULTI USE SERIES

CAREFREE BRAKE TECHNOLOGY 不須費心保養
FOR TRIAL PERFORMANCE 專為攀岩車設計
HUGE BRAKING POWER FOR TRIAL BIKES
強大的制動力道為攀岩車款最佳首選

HS33 R FIRMTECH

The HS33 R FIRMtech is the first hydraulic rim brake with its own fastening geometry, ensuring the simplest possible fitting and maximum rigidity combined with reduced weight.

HS33 R FIRMtech是輪圈煞中，
第一個擁有獨特的緊固幾何，盡可能簡化安裝步驟，
同時在減輕重量之餘還能保有最大剛性。

Weight (g) 重量	290
Master 本體	Carbotecture® 高科技纖維複合材質
Lever Blade 拉柄	Aluminium 鋁合金
Reach Adjust 握距調整	Tool T25 T25星形螺絲起子
Bite Adjust 煞車塊間隙調整	TPA 調整鈕
Lever Blade 煞車拉柄	2-Finger; opt.: 4-Finger, 2-指選配:4-指 3-Finger ball-end 3-指加圓頭
Mounting 煞車固定座	FIRM 攀岩車固定座
RRP (€) 建議售價(歐元)	109,90
Order No. 產品編號	2700 315



MULTI USE SERIES

DIRECT MOUNTING 可直接安裝
SPORTY DESIGN 運動風設計
HUGE BRAKING POWER FOR RIM BRAKES 擁有最強勁的煞車力道

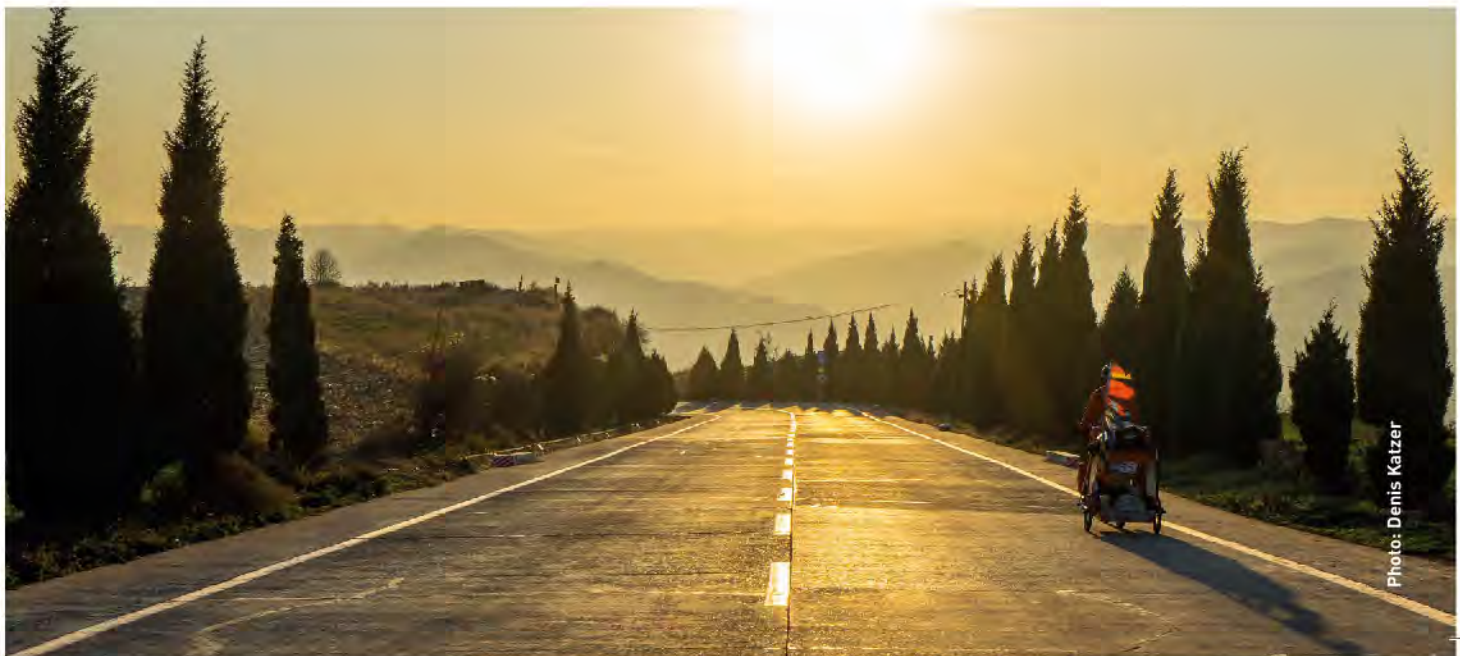

RT6 TT

Hydraulic brake system for the road. Light and aerodynamic, it sets new standards. The hydraulic tubing, with their friction-free routing are a real bonus that also deliver uniform braking power to both wheels.

公路液壓煞車系統。輕量化、具空氣動力學的新穎設計，樹立全新標竿。液壓傳動的優點，能避免煞車作動時因煞車油管的摩擦而影響力量的傳遞，輸出的力量更為直接。

Weight (g) 重量	280* (average value 平均值)
Master 本體	Aluminium 鋁合金
Lever Blade 拉柄	Aluminium 鋁合金
Reach Adjust 握距調整	Tool allen2
Lever Blade 煞車拉柄	2-Finger 2 指
Mounting 煞車固定座	Center Bolt 中鎖式固定座
RRP (€) 建議售價(歐元)	499,00 (Set)
Order No. 產品編號	0 141 128 ^a



COMPETITION SERIES

AERODYNAMICS BY CERVÉLO 符合CERVÉLO空氣動力學
HIGH BRAKING POWER 絕佳煞車制動力

^a2 700 257: 275,00 € VR / 2 700 258: 275,00 € HR





E-BIKE BRAKES 電動自行車煞車



E-BIKE SWITCH

Activates brake light and controls the motor cut-off

電動自行車開關

可控制煞車燈及截斷電控馬達



BRAKE POWER

4 pistons for maximum braking power and stability

煞車制動力

4活塞卡鉗提供最強大的制動力及穩定性



BALL END LEVER

For safe grip at the lever

圓球拉柄

符合電動車及電助車的安全性規範

MT5e

Brakes everything, including the motor – experience from the motorbike sector paired with e-bike know-how.

The braking force of the 4 pistons and high stability ensure s-pedelecs benefit from more safety. Guaranteed.

與電動煞車息息相關的，包含馬達—

結合了電動摩托車的經驗及電動自行車的專業知識。

4活塞制動力及高穩定性，確保s-pedelecs擁有更高安全性。

Weight (g) 重量	399*
Master 本體	Carbotecture® 高科技纖維複合材質
Lever Blade 拉柄	Aluminium with switch 鋁合金，搭配開關
Reach Adjust 握距調整	Tool allen3 3號內六角板手
Bite Adjust 靈敏度調整	-
Pistons 活塞	4
Mounting 卡鉗固定座	PM/IS
RRP (€) 建議售價(歐元)	139,90**
Order No. 產品編號	2700 984*

E-BIKE



SPEED eMOBILITY SERIES

GENES OF THE MT7 承襲MT7不凡基因
E-BIKE TECHNOLOGY 電動自行車科技

MT4e

Here, safety is spelled 4e: even before braking starts, a switch of the MT4e activates the brake light and/or cuts off the motor.

Our all-round disc brake with all the features needed by e-bikes.

在這裡，4e就是安全性的代名詞。早在煞車作動前，

MT4e就已準備好啟動煞車燈或截斷電控馬達。

充分展現自己在電動車領域的全能特點。

Weight (g) 重量	370*
Master 本體	Carbotecture® 高科技纖維複合材質
Lever Blade 拉柄	Aluminium with switch 鋁合金，搭配開關
Reach Adjust 握距調整	Tool allen3 3號內六角板手
Bite Adjust 靈敏度調整	-
Pistons 活塞	2
Mounting 卡鉗固定座	PM/IS
Not available in the aftermarket. 暫不適用於補修市場	

E-BIKE



SPEED eMOBILITY SERIES

E-BIKE TECHNOLOGY 電動自行車科技
PERFECT ALL-ROUNDER 完美全能型煞車

* 2700 984: HIG0-Closer海固接頭-長開 / 2700 985: HIG0-Opener海固接頭-長閉

HS33 Re

The HS33 Re is the hydraulic rim brake that is specially designed for e-bikes. With increased braking power and perfect ergonomics, the ideal partner for town and country, e-bike or s-pedelec.

HS33Re是專為電動自行車所設計的液壓輪圈煞車，具備了更強的煞車力道與更完備的人體工學設計，為城市車、電動自行車與電動車的理想選擇。

Weight (g) 重量	485
Master 本體	Carbotecture® 高科技纖維複合材質
Lever Blade 拉柄	Aluminium with switch 鋁合金，搭配開關
Reach Adjust 握距調整	Tool T25 T25星型扳手
Bite Adjust 煞車塊間隙調整	TPA 調整鈕
Lever Blade 拉柄	4-Finger ball-end with switch 4指圓球，搭配開關
Mounting 煞車固定座	Cantilever EVO2 EVO2固定座
Not available in the aftermarket. 暫不適用於補修市場	



E-BIKE

SPEED eMOBILITY SERIES

E-BIKE TECHNOLOGY 電動自行車科技

THE LATEST MODEL OF THE CAREFREE BRAKE RANGE 全新推出的輪圈煞車

ELEGANT DESIGN AND HIGH-QUALITY MATERIALS 高質感設計

MORE BRAKES, WE RECOMMEND FOR E-BIKES: 更多電動煞車選擇，推薦您使用:



MT5

Order Number	RRP (€)
產品編號	建議售價(歐元)
2 700 477	109,90**



MT4

Order Number	RRP (€)
產品編號	建議售價(歐元)
2 700 476	89,90**



HS33 R

Order Number	RRP (€)
產品編號	建議售價(歐元)
2 700 245	109,90
2 700 246	109,90
2 700 247	109,90



HS22

Order Number	RRP (€)
產品編號	建議售價(歐元)
2 700 845	89,90
2 700 846	89,90



HS11

Order Number	RRP (€)
產品編號	建議售價(歐元)
2 701 214	69,90
2 701 252	69,90

* incl. 160 mm rotor and screws, without adapter * 包含160mm碟盤及螺絲，不含轉接座
** without rotor/adaptor ** 不含碟盤/轉接座



Photo: Philipp Ruopp

Overview Brakes 煞車總覽

- » All weights +/- 5%
商品重量標示 +/- 5%
- » Compatible with all standard Shimano STI, SRAM Trigger, SRAM and Rohloff twist-grip shifters
相容於標準Shimano STI變速系統，SRAM變速撥把，SRAM及Rohloff變速轉把
- » 5 year leak proof warranty on brake levers and brake calipers
煞車把手及卡鉗，提供5年防漏保固
- » ^A Averaged weight of front and rear brake
平均重量，前煞+後煞
- » ^B Weight per brake 每條煞車重量
- » ^C averaged weight of front and rear brake, without pads
平均重量，前煞+後煞，不含來令片
- » ^D Recommendation

- » ^E Without rotor, without adapter
不包含碟盤，不包含轉接座
- » Specifications are subject to change without prior notice
規格如有變更，恕不另行通知

OVERVIEW BRAKES 煞車規格總覽

		MT Trail Carbon	MT8 Carbon	MT7	MT5	MT6	MT4	MT2	HS33 R	HS33 R FIRMtech	HS33 R Trial	HS22	HS11	RT6 TT
Applications 適用車種	MTB	•	•	•	•	•	•	•	•	•	•	•	•	
	Trekking/City Road						•	•	•	•	•	•	•	•
	E-Bike				•(e)		•(e)		•(e)			•	•	
Weight (g) 重量(g)		330 ^A	299 ^B	375 ^B	380 ^B	320 ^B	350 ^B	365 ^B	465 ^B	290 ^B	320 ^B	440 ^B	425 ^B	280 ^C
Material 材質	Master 本體	Carbotecture SL	•	•		•								
	Lever Blade 拉柄	Carbotecture [®]				•	•	•	•	•	•	•	•	
Caliper 卡鉗	Aluminium													•
	Aluminium	•	•		•	•	•	•	•	•	•	•	•	•
Hydraulic 液壓		•	•	•	•	•	•	•	•	•	•	•	•	•
Brake medium 煞車傳動媒介	Royal Blood 皇家血統礦物油	•	•	•	•	•	•	•	•	•	•	•	•	•
Features 技術特點	EBT 易注油技術	•	•	•	•	•	•	•	•	•	•	•	•	•
	BAT/TPA 煞車靈敏度/煞車塊間隙調整			•					•	•	•	•		
	Brake 補強片								•			•		
	Banjo fitting Caliper 可調式油管	•	•	•	•	•	•							
	2 Pistons 2活塞 rear	•	•			•	•	•						
	4 Pistons 4活塞 front			•	•									
	Reach Adjust 握距調整	Tool 需工具	•	•		•	•	•	•	•	•		•	•
	Manual 免工具			•		•						•		
	Flip-Flop 左右共用	•	•	•	•	•	•	•	•	•	•	•	•	•
	Shift Mix 棘變把整合式固定環	opt.	opt.	opt.	opt.	opt.	opt.	opt.	opt.	opt.	opt.	opt.	opt.	opt.
Remote Mix 整合式固定環	opt.	opt.	opt.	opt.	opt.	opt.	opt.	opt.	opt.	opt.	opt.	opt.	opt.	
Rotor ^D 碟盤	Storm SL		•			•								
	Storm HC	•		•	•	•	•	•						
Pad mounting 來令片安裝	Magnet with Pin	•	•	•		•	•	•						
	Magnet w/o Pin				•									
	HS EPR								•	•	•	•	•	
Lever Blade 煞車拉柄	Standard Cartridge													•
	1-Finger HC	opt.	opt.	opt.	opt.	opt.	opt.							
	2-Finger	•	•	•	•	•	•	•	•	•	•			•
	3-Finger											•	•	
	4-Finger			opt.	opt.	opt.	opt.		opt.	opt.	opt.			
	2-Finger ball-end			opt.	opt.	opt.	opt.							
	3-Finger ball-end				opt.(e)		opt.(e)		opt.(e)	opt.	opt.			
4-Finger ball-end			opt.	opt.	opt.	opt.								
Tubing 油管	MAGURA disc tube	•	•	•	•	•	•							
	MAGURA tube							•	•	•	•	•	•	•
Switch Mounting 卡鉗固定座	PM/IS	•	•	•	•	•	•							
Colours 顏色	Canti							•	FIRM	IDM	•	•		
	Center Bolt													•
	Master	■	■	■	■	■	■	■	■	■	■	■	■	■
	Master Print/Cover	■	■	■	■	■	■	■	■	■	■	■	■	■
Caliper	■	■	■	■	■	■	■	■	■	■	■	■	■	
Caliper Cover	■	■	■	■	■	■	■	■	■	■	■	■	■	
RRP (€) ^E 建議售價(歐元)		579,90 (Set)	279,90	219,90	109,90/139,90(e)	179,90	89,90	54,90	109,90	109,90	109,90	89,90	69,90	499,00 (Set)

■ black 黑
 ■ mystic grey 神秘灰
 ■ chrome 鍍鉻
 ■ silver 銀
 ■ blue 藍
 ■ neonyellow 霓虹黃
 ■ white 白
 ■ neonred 霓虹紅
 ■ chrome 鍍鉻
 ■ blue 藍
 ■ neonyellow 霓虹黃
 ■ white 白
 ■ neonred 霓虹紅

SEATPOST 無線伸縮座管



STEPLESS ADJUSTMENT

Its stepless adjustment range of 150 mm lets you select the ideal saddle position for the conditions you are riding in, be it trail or flat road.

無段式調整

行程150mm，具有無段式調整功能。無論馳騁於任何地形，您都可更快速地將座墊調整到您想要的高度。

VYRON eLECT SEATPOST

No cables, no laborious cable routing. The VYRON eLECT Seatpost with wireless remote control is a technical trailblazer and received 'Gold' in the Design & Innovation Award 2016.

沒有走線的束縛，更不須您費心保養。Vyron eLECT無線遙控伸縮座管系統以其高科技技術，榮獲2016創新設計獎的金質獎殊榮。

Weight (g) 重量	595
Material 材質	black-anodized 黑色陽極
Length (mm) 長度	446
Diameter (mm) 直徑	30,9; 31,6
Travel (mm) 行程	150 mm variable positioning 150mm 無段式調整
Charging unit 充電插座	Micro-USB
Charging time 充電時間	app. 3 h 約3小時
Charge after 充電後	app. 400 uses 約可使用400次
Remote Trigger 控制媒介	Wireless Remote Control 無線遙控
RRP (€) 建議售價	400,00
Order No. 產品編號	2 700 931; 2 700 932 ⁹

TRAIL SERIES

GAMECHANGER 突破規限

STEPLESS ADJUSTMENT 無段式調整

PLUG N PLAY 隨插即用



⁹ 2 700 931: Ø 30,9 mm / 2 700 932: Ø 31,6 mm

SUSPENSION 避震前叉

TS TECHNOLOGY TS 獨家技術

DAMPING VARIATIONS Compression units
壓縮阻尼



eLECT
Wireless manual mode
全自動模式 / 無線手動模式



DLO³
Highest sensitivity
全開模式
Reduced sensitivity
平台模式
Locked with blow off for greater stiffness
鎖死模式



DLO²
Open: Highest sensitivity
全開模式: 提供最靈敏的壓縮作動
Close: Locked with blow off
鎖死模式: 洩壓鎖死功能



DOUBLE ARCH DESIGN
High torsional stiffness
獨家雙拱橋設計
強化下管抗扭力剛性



LIGHTWEIGHT CROWN
Weight-saving crown
輕量化肩蓋
節省更多重量



M15
15mm thru-axle with T25 tool for greater stiffness
15mm 穿插軸整合T25工具
提供絕佳的剛性



RCL² REMOTE
Ergonomic remote for DLO²
RCL²線控器
可直接從車把手操控鎖死系統DLO²



REMOTE MIX
Mounting of RCL² Remote and brake master with one clamp
線控器整合式固定環
可整合RCL²線控器與MAGURA煞把

TS R/RC TECHNOLOGY TS R/RC 獨家技術



TS RC

Highest sensitivity
全開模式: 提供最靈敏的壓縮作動
Reduced sensitivity
平台模式: 靈敏度適中
Locked with blow off
鎖死模式: 洩壓鎖死功能



eLECT MODULE

eLECT module for automatic adjustment on the trail

eLECT模組

eLECT模組能感測路況
自動控制鎖死開關



TRAVEL

Different fitting lengths available

避震行程

提供多種行程選擇



TS8 eLECT

The elec-tronically controlled lockout-function of the TS8 suspension forks. eLECT automatically adjusts the lockout depending on the riding situation. Manual control via a wireless remote is also possible.

經由電子控制鎖死系統的TS8智能化避震前叉，其eLECT智能模組，在自動模式的狀態下，能感測當下的騎乘路況，自動調整鎖死功能。透過無線遙控器的設定，也能隨時切換到手控模式。

Weight (mm) from 重量(g)	1625
Travel (mm) 避震行程(mm)	100, 120, 150
Wheel size 輪組尺寸	27,5", 29"
Damping 阻尼技術	eLECT 智能模組
Remote 控制器	wireless 無線遙控
Brake mounting 煞車固定座	PM 7"
RRP (€) 建議售價(歐元)	799,00

COMPETITION SERIES

AUTOMATICALLY IN YOUR MODE 可切換為自動模式

DOUBLE ARCH DESIGN 雙拱橋設計

LIGHTWEIGHT 輕量化



TS R eLECT

Automatic lockout that is electronically controlled depending on the riding situation. Manual mode - the lockout function can be controlled separately via the wireless remote.

內建的智能模組能感測當下的騎乘路況，自動調整鎖死系統。手控模式 - 透過無線遙控器的切換，能獨立控制鎖死系統。

Eye to eye length (mm) 眼對眼長度(mm)	165	190	200	215
Adjustability 可調性	eLECT, lockout, wireless/auto 智能連接, 鎖死模式, 無線遙控/自動			
Travel (mm) 避震行程(mm)	38	51	56	63
Weight (g) 重量(g)	255	272	280	288
Not available in the aftermarket. 暫不適用於補修市場				

COMPETITION SERIES

AUTOMATICALLY IN YOUR MODE 可切換為自動模式

ADJUSTABLE CUSHIONING CHARACTERISTICS 可調式的緩衝性能

WIDE AREA OF USE 廣域使用



eLECT-UPGRADE KIT eLECT智能升級套件組

For all MAGURA forks (MY 2010+)
Content: eLECT Control Unit, eLECT Remote, Mounting Kit, Charging Kit, Fitting Tool.

適用於MY2010後所有瑪古拉前叉型號
內容物: eLECT智能模組、eLECT遙控器、安裝工具組、充電組

Order Number 產品編號	RRP (€) 建議售價(歐元)
2 700 571	349,00

TS8

100 to 150 mm suspension forks with 15 mm through axle. The double arch design and thru-axle enable high rigidity combined with low weight. The ideal suspension fork for racers and demanding touring riders.

TS8避震前叉提供100至150行程，配置15mm穿插軸，雙拱橋設計與穿插軸的搭配，使前叉同時具備高剛性與輕量化特性。是為競賽型車手與長旅騎乘者的理想選擇。

Weight (g) from 重量	1630
Travel (mm) 避震行程(mm)	100, 120, 150
Wheel size 輪組尺寸	27.5", 29"
Damping 阻尼技術	DLO ² , DLO ³ *
Remote 控制器	cable** 線控**
Brake mounting 煞車固定座	PM 7"
RRP (€) from 建議售價(歐元)	549,00

BOLTRON

Upside-Down fork, especially developed for E-MTBs. Thanks to 40 mm outer tubes and 20 mm thru axle the fork has the necessary rigidity for full suspension e-bikes.

倒立式前叉，特別適用於電動登山車，以40mm的外管搭配上20mm穿插軸，提供全避震電動登山車所需更強化的剛性。

Weight (g) 重量	2200
Travel (mm) 避震行程(mm)	120, 150
Wheel size 輪組尺寸	29", 650B+
Damping 阻尼技術	-
Remote 控制器	-
Brake mounting 煞車固定座	PM 7"
Not available in the aftermarket. 建議售價(歐元)	



COMPETITION SERIES

LIGHTWEIGHT 輕量化

DOUBLE ARCH DESIGN 雙拱橋設計



SPEED eMOBILITY SERIES

UPSIDE DOWN TECHNOLOGY 倒立式設計

20 MM THRU AXLE 20mm貫通軸

STIFF 超強剛性

* DLO² = 100/120 mm travel DLO³ = 150 mm travel
** 100/120 mm travel



OVERVIEW FORKS

規格總覽 避震前叉

Model		TS8	TS8	TS8	TS8	TS8	BOLTRON	BOLTRON
Travel (mm) 避震行程(mm)		100	100	120	120	150	120	150
Wheel size 輪組尺寸	27,5"	•		•		•		
	29"		•		•		•	•
	650B+						•	•
Damping 阻尼技術	eLECT	•	•	•	•	•		
	DLO ³					•		
	DLO ²	•	•	•	•			
Dropout (mm) 鈎爪(mm)		15 ^E	15 ^E	15 ^E	15 ^E	15 ^E	20 ^F	20 ^F
Steerer 頭管規格	1 1/8"	•	•	•	•	•	•	•
	-1,5"							
Remote 控制器	wireless	•	•	•	•	•		
	cable	•	•	•	•			
Fork length (mm) 前叉長度(mm)		489	510	510	530	539	530	560
Brake mounting 碟煞固定座	PM 7"	•	•	•	•	•	•	•
Applications 適用車種	CC	•	•					
	Marathon	•	•	•	•			
	AM/Trail			•	•	•		
	E-MTB						•	•
Colours 顏色	mat	•	•	•	•	•	•	•
			•					
Weight (g) from 重量(g)		1630	1665	1650	1725	1685	2200	2200
RRP (€) from 建議售價(歐元)			549,00 / eLECT: 799,00				*	*

SUSPENSION 避震前叉

- » * Not available in the aftermarket
- » Optimal compression damping due to improved shim tuning
經改良的墊片，優化壓縮阻尼
- » Double butted 32 mm Stanchions (TS8), 40 mm outer tube (BOLTRON)
雙倍厚實的32mm內管(所有前叉)
- » Approved for rotors up to 210 mm
- » All weights +/- 5% 商品重量標示 +/- 5%
- » ^EM15 thru-axle 15x100 (TS8), M20 thru-axle 20x110 (BOLTRON)
M15穿軸軸 15 x 100 (TS8) • M20穿軸軸 20 x 110 (BOLTRON)
- » Specifications are subject to change without prior notice
規格如有變更，恕不另行通知

More information on magura.com
更多資訊，請參訪 magura.com

BRAKE PADS 煞車來令片

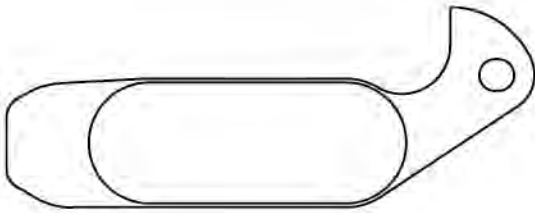

1.2
Gustav M MJ 2000-2011



2.1/2.2
Clara MJ 2000-2001
Louise MJ 1999-2001

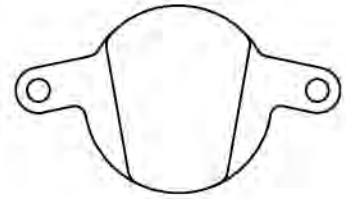

3.1/3.2
Clara MJ 2002
Louise/FR MJ 2002-2006

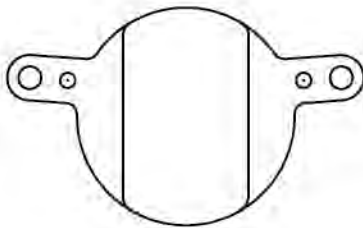

4.1/4.2
Julie MJ 2001-2008



5.1/5.2
Marta MJ 2002-2008
Marta SL MJ 2003-2008

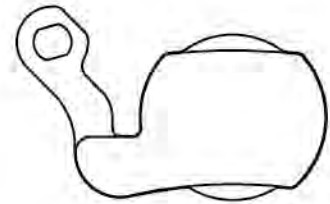

6.1/6.2
Louise MJ 2007-2011
Julie HP MJ 2009-2011
Marta/ SL/FR MJ 2009-2011

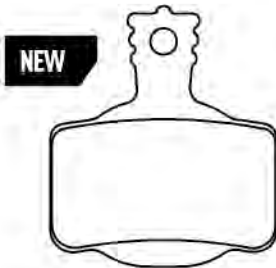

7.P/7.C/7.R
MT2/MT4/MT6/MT8 ab from MJ 2012



8.P/8.R
MT5/MT7 ab from MJ 2015



9.P/9.C
MT5/MT7 ab from MJ 2015

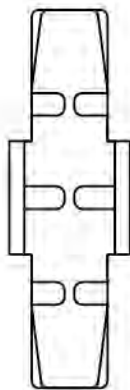

BLACK

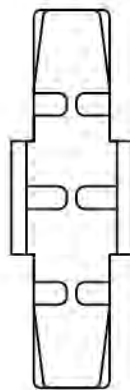

GREY

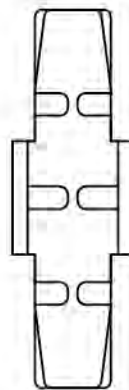

GREEN

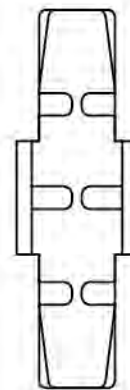

RED

DISC BRAKE PADS 碟煞來令片

PERFORMANCE

NEW



For long tours these pads offer safety together with excellent performance in all situations.

功效型，適用於長途旅行，在任何路況下，都能提供穩定、安全的制動表現。



Only available for brake pad 7., 8. and 9. 僅適用於來令片7,8,9

COMFORT

NEW



For riders who want control rather than bite from their brakes as well as those looking for a long-lasting product.

舒適型，提供平穩的煞車操控，適合尋求溫和制動力的車友，來令片使用壽命較長



Only available for brake pad 7. and 9. 僅適用於來令片7,8,9

RACE

NEW



For all those who bring their material to the limits during cross country or downhill and require outstanding braking performance.

競賽型，提供最大制動力道，適用下坡車或較激烈的越野路況。



* leichte Abweichung bei 8.R

Only available for brake pad 7. and 8. 僅適用於來令片7,8,9

X.1

= Performance 制動性能

The brake pad is characterized by maximum braking power. 以協助煞車發揮強大的制動性能為特色

X.2

= Endurance 耐久性

The brake pad is characterized by optimized durability.

來令片的特徵是優化的持久性，以提供平穩的煞車操控為特色
Only available for brake pad 1. to 6. 僅適用於來令片1到6.

Safety note initial braking

Caution correct initial braking! Rule of thumb: Brake from a speed of 30 km/h to zero 30 times. Important, when the rotor and pads are new.

■ If only the pads or rotor are new the time and effort will be reduced.

安全性提醒 - 煞車磨合

■ 請以謹慎、正確的方式進行煞車磨合！經驗法則：在碟盤及來令片皆為全新的狀態時，請將自行車加速到30 km/h後，按壓煞車，重複執行磨合動作至少30次以上。

■ 若只有來令片或碟盤，其一為新，將可減少磨合次數。

RIM BRAKE PADS 輪圈煞來令片

Check your rim type!

依您使用的輪圈做挑選!

BLACK

RED

For uncoated aluminium rims.

適用於無塗層的鋁製輪圈

GREY

GREEN

For hard coated aluminium and ceramic rims.

適用硬質塗層的鋁製輪圈及陶瓷輪圈



BLACK

GREY

High durability - Whether a day trip or a trip around the world. You'll only have to think about servicing your brake afterwards.

高耐用性 - 無論是一日遊還是世界各地的旅行，你只需要考慮結束後如何保養你的煞車。

RED

GREEN

Your bike is daily in use in all weather conditions. Many traffic lights and stops require the maximum power of your brakes.

適合每天的單車通勤，能適應各種天氣狀況。在走走停停的交通號誌下，都能發揮強大的煞車力道。

SPARE PARTS 原裝配件

BRAKE PADS 煞車來令片



BREMSBELAG 9.P/9.C 來令片

Compatible with MT5/MT7 from MY 2015
適用於2015年以後生產的 MT5/ MT7

Description 產品描述	Order Number 產品編號	RRP (€) 建議售價(歐元)
9.P Performance 功效型	2 701 166	19,90
9.C Comfort 舒適型	2 701 169	15,50



BREMSBELAG 8.R/8.P 來令片

Compatible with MT5/MT7 from MY 2015
適用於2015年以後生產的 MT5/ MT7

8.R Race 競賽型	2 701 173	29,90
8.P Performance 功效型	2 701 171	22,90



BREMSBELAG 7.R/7.P/7.C 來令片

Compatible with MT2/MT4/MT6/MT8 from MY 2012
適用於2012年以後生產的 MT2/ MT4/MT6/MT8

7.R Race 競賽型	2 701 179	24,90
7.P Performance 功效型	2 701 175	19,90
7.C Comfort 舒適型	2 701 177	15,50



BREMSBELAG 6.1/6.2 來令片

Compatible with Louise from MY2007/Julie HP from MY2009/Marta/SL/FR MJ 2009-2011
適用於2007年以後生產的 Louise/2009年以後生產的 Julie HP/Marta/SL/FR MJ 2009-2011

6.1 Performance 功效型	0 721 418	22,90
6.2 Endurance 耐久型	0 721 419	22,90

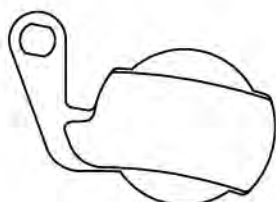

BREMSBELAG 5.1/5.2 來令片

Compatible with Marta MJ 2002-2008/Marta SL MJ 2003-2011
適用於Marta MJ 2002-2008/ Marta SL MJ 2003-2011

5.1 Performance 功效型	0 721 340	22,90
5.2 Endurance 耐久型	0 721 672	22,90

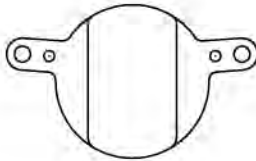

BREMSBELAG 4.1/4.2 來令片

Compatible with Julie MJ 2001–2008
適用於 Julie MJ 2001–2008

Description 產品描述	Order Number 產品編號	RRP (€) 建議售價(歐元)
4.1 Performance 功效型	0 721 304	22,90
4.2 Endurance 耐久型	0 721 684	22,90

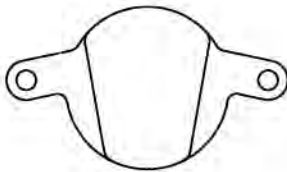

BREMSBELAG 3.1/3.2 來令片

Compatible with Clara MJ 2002/Louise/FR MJ 2002–2006
適用於 Clara MJ 2002/Louise/FR MJ 2002–2006

3.1 Performance 功效型	0 721 324	22,90
3.2 Endurance 耐久型	0 721 682	22,90

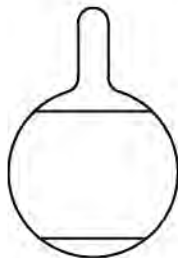

BREMSBELAG 2.1/2.2 來令片

Compatible with Clara MJ 2000–2001/Louise MJ 1999–2001
適用於 Clara MJ 2000–2001/Louise MJ 1999–2001

2.1 Performance 功效型	0 721 003	22,90
2.2 Endurance 耐久型	0 721 056	22,90

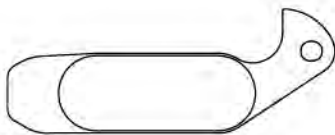

BREMSBELAG 1.1/1.2 來令片

Compatible with Gustav M MJ 2000–2011
適用於 Compatible with Gustav M MJ 2000–2011

1.2 Endurance 耐久型	0 721 018	22,90
-------------------	-----------	-------



BREMSBELAG 來令片

Compatible with HS11/HS22/HS33 R/HS33 R Trial/HS33 R FIRMtech
適用於 HS11/HS22/HS33 R/HS33 R Trial/HS33 R FIRMtech

black 黑色	0 321 406	19,90
grey 灰色	0 321 407	19,90
red 紅色	0 720 423	23,90
green 綠色	0 720 439	23,90

ROTORS 碟盤



STORM SL 風暴超輕

The lightest rotor combining great brake performance with minimal weight.
擁有結合絕佳的制動性能與最輕的重量

Diameter (mm) 尺寸	Weight (g) 重量	Order Number 產品編號	RRP (€) 建議售價
140	75	0 724 401	35,00
160	95	0 724 402	35,00
180	122	0 724 403	35,00
203	153	0 724 404	35,00



STORM HC 風暴.HC

The Storm HC rotor designed for extreme use for unparalleled braking performance under high braking forces.

風暴.HC 專為極端的操駕而設計，提供您無與倫比的制動性能表現

160	127	2 700 928	30,00
180	148	2 700 929	30,00
203	182	2 700 930	30,00



MAGURA DISC 瑪古拉碟盤

The entry level rotor to the MAGURA rotor selection. High performance with low noise production.

瑪古拉的最佳入門款碟盤，高效能與低噪音的優秀產品。

180	179	2 700 709	20,00
-----	-----	-----------	-------

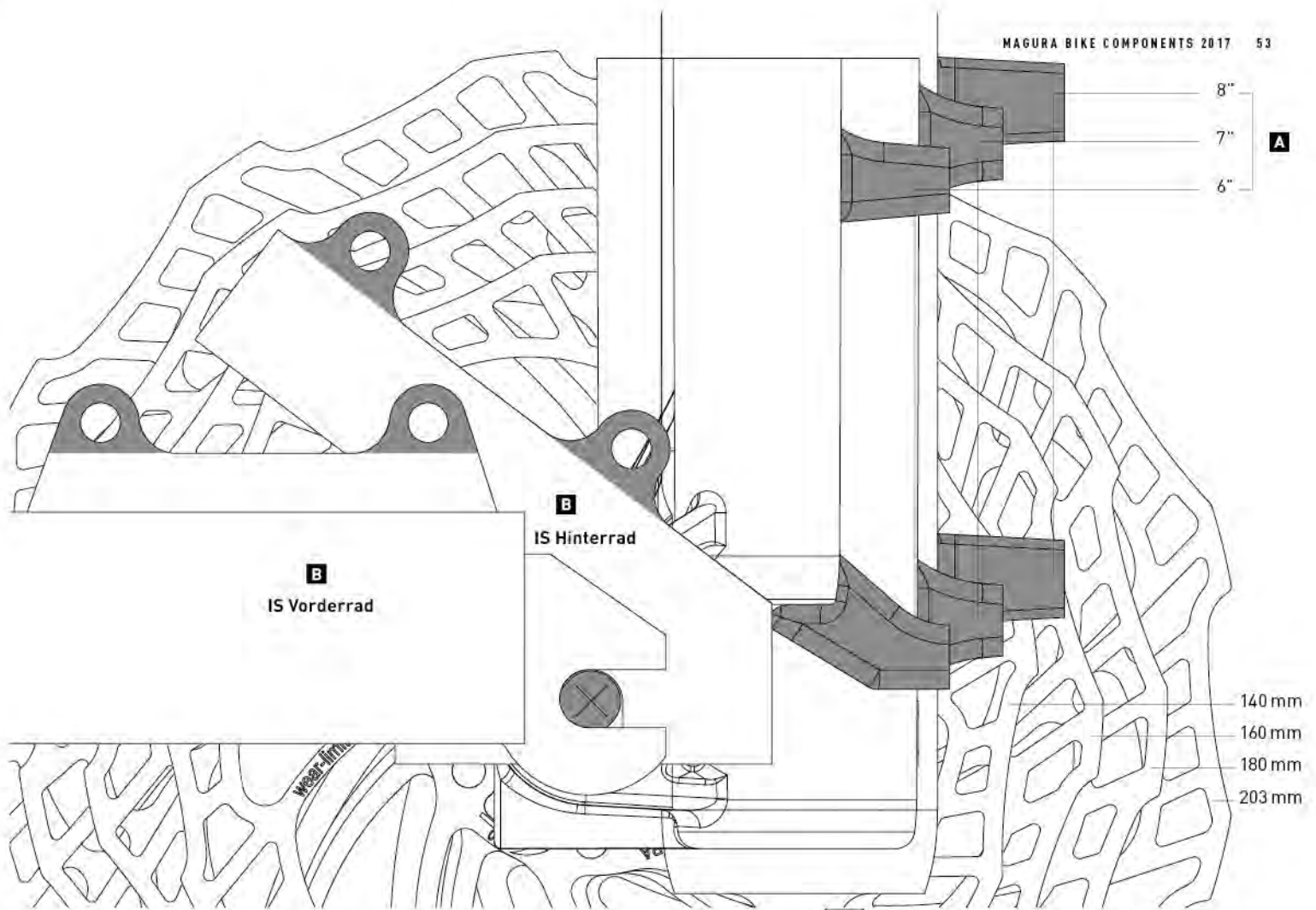

MAGURA MOUNTING GUIDE

ANWENDUNG

So verwenden Sie diese Grafik: Richten Sie den Mittelpunkt »X« auf das Zentrum des Ausfallendes von Rahmen oder Gabel aus und drehen Sie, bis die Zeichnung mit dem Rahmen oder der Gabel übereinstimmt.

POST MOUNT VARIANTEN

A. PM, 74 mm Mitte / Mitte

Entstanden als eine Alternative zum internationalen Standard im Jahr 1997, ist die PM Aufnahme in den letzten 5 Jahren populär geworden, sowohl an Gabeln als auch an Rahmen, insbesondere aufgrund seiner Benutzerfreundlichkeit. Es wird hauptsächlich zwischen drei PM Größen unterschieden: Bei 6" passt eine 160 mm Scheibe ohne Adapter. Bei 7" passt eine 180 mm Scheibe und bei 8" eine 203 mm Scheibe. Es gibt Rahmen mit einer 5"-Aufnahme, die entsprechend mit einer 140 mm Scheibe ohne Adapter direkt gefahren werden.

» Alle PM Aufnahme-Größen passen zu Standard PM Bremssätteln.

INTERNATIONALE STANDARD VARIANTEN

Internationale Standard Varianten

B. IS 6", 51 mm Mitte / Mitte

War die Standardaufnahme für fast alle Gabeln und Rahmen zwischen 1999 und 2008 (außer Manitou Gabeln etc.). Vorder- und Hinterrad unterscheiden sich.

C. IS 8" (nur IS Vorderrad), 51 mm Mitte / Mitte

Bis vor ein paar Jahren auf einigen DH Gabeln und Rahmen wie Marzocchi Monster, 888 und Fox 40 verwendet.

» Bei IS 8" passt 203 mm als kleinster Scheibendurchmesser.

D. RockShox Boxxer (nur IS Vorderrad), 51 mm Mitte / Mitte

Ähnlich IS 8". Diese Aufnahme wurde fast nur auf der RockShox Boxxer Gabel bis 2010 eingesetzt.

» Für diese Aufnahme benötigt man einen speziellen Boxxer-Adapter

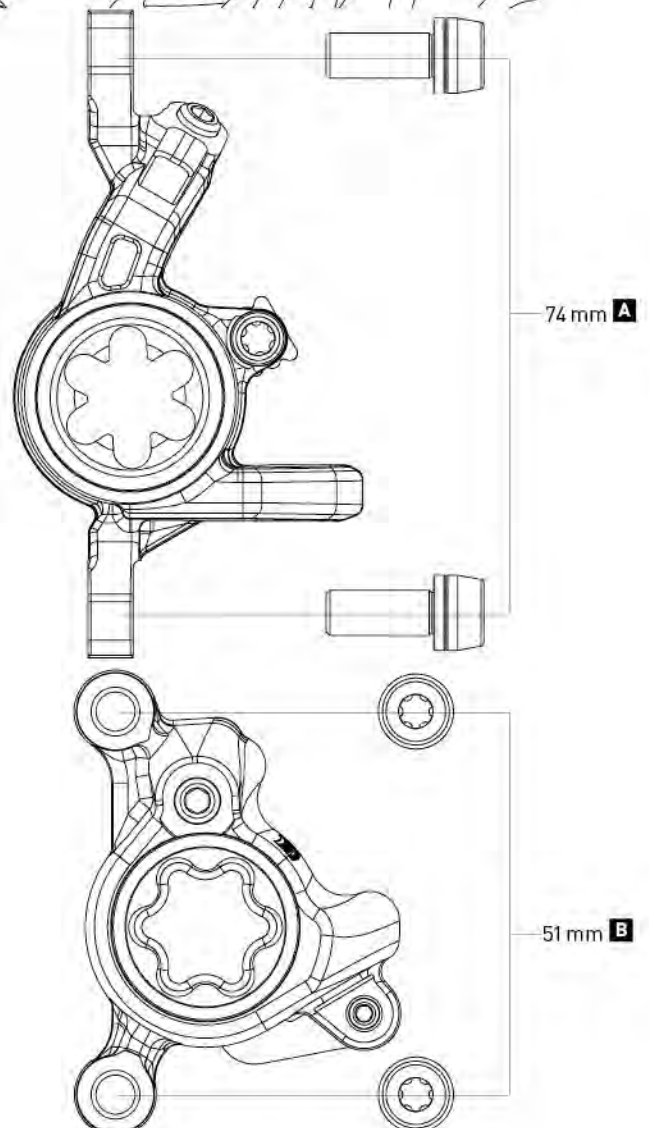

HANDLEBAR CLAMP 煞把固定環



SHIFTMIX CLAMP 整合式固定環



Description 敘述	Order Number 產品編號	RRP (€) 建議售價(歐元)
Shiftmix 1+2, für Shimano I-Spec I+II links u. rechts (Paar) for Shimano I-Spec I+II left and right (pair)	2 701 241	39,90
Shiftmix 1+2, für Shimano I-Spec I+II links for Shimano I-Spec I+II left	2 701 242	20,90
Shiftmix 1+2, für Shimano I-Spec I+II rechts for Shimano I-Spec I+II right	2 701 243	20,90
Shiftmix 3 für SRAM Trigger links u. rechts (Paar) for SRAM Trigger left and right (pair)	0 724 710	39,90
Shiftmix 3 für SRAM Trigger links for SRAM Trigger left	2 700 840	20,90
Shiftmix 3 für SRAM Trigger rechts for SRAM Trigger right	2 700 841	20,90

CLAMP 固定環規格

Aluminium, neon-gelb Upgrade, ohne Schrauben yellow ex bolts (VE = 1 Stück/pc)	2 700 751	11,90
Aluminium, neon-rot Upgrade, ohne Schrauben red ex bolts (VE = 1 Stück/pc)	2 700 752	11,90
Aluminium, cyan-blau Upgrade, ohne Schrauben blue ex bolts (VE = 1 Stück/pc)	2 700 753	11,90
Carbolay, ohne Schrauben ex bolts (VE = 1 Stück/pc)	0 724 709	20,90
RemoteMix für RCL ² , schwarz black (VE = 1 Stück/pc)	0 724 712	19,90
Aluminium, schwarz, ohne Schrauben black, ex bolts (VE = 1 Stück/pc)	0 724 488	9,90
Aluminium, silber, ohne Schrauben silver, ex bolts (VE = 1 Stück/pc)	0 724 489	9,90
Carbotecture®, schwarz, ohne Schrauben black, ex bolts (VE = 1 Stück/pc)	2 700137	7,90
Carbotecture®, silber, ohne Schrauben silver, ex bolts (VE = 1 Stück/pc)	2 700 136	7,90

DIVERS



ROYAL BLOOD 皇家血統礦物油

Description 敘述	Order Number 產品編號	RRP (€) 建議售價(歐元)
MAGURA Royal Blood, 100 ml	0 721 630	6,50
MAGURA Royal Blood, 250 ml	0 721 632	17,50
MAGURA Royal Blood, 1000 ml	0 721 631	33,50



FORK MEISTER GREASE 前叉潤滑油膏

for bushings from MY 2012 2012年之後生產之軸機使用	0 724 807	24,90
---	-----------	-------



SUSPENSION BLOOD 前叉潤滑油

Suspension Blood Typ 2 SAE 5ISOVG 25, Dämpfungslöl, 500 ml damping oil	0 731 120	13,90
lubrication oil 潤滑油	0 722 482	19,90



SERVICE KIT 保養維修組

Service Kit for disc and rim brakes, Contents: 100 ml Royal Blood, 2 x syringes incl. hose, Torx T25 tool, 2 x installing clamps, small parts and inserts for tubing shortening 煞車維修配件包，內含： 100ml 皇家血統礦物油，2個注油針筒及針管， T25星型扳手，2個安裝固定座，剪管用的油針及小零件。	2 700 191	33,00
Pro-Bleed Kit EBT, (for disc and rim brakes) 專業灌油組	0 724 492	46,90



APPAREL

RIDE & RELAX

Apparel and Accessories – powered by MAGURA & Maloja

The MT7 disc brake and the VYRON eLECT seatpost send out a clear signal that MAGURA is entering a new era – “Changing the Game”. With multiple awards, the MAGURA hardware is already highly successful and this spring will be enhanced with a completely new MAGURA collection of functional clothing, streetwear and accessories. Maloja is the new business partner who will provide the ideal style and quality for our clothing lines.

Two MAGURA collections with more than 30 items offer a rich selection. “MAGURA by Maloja” offers functional garments with a fresh MAGURA look for riders, from Cross Country to Enduro. Our own small, top-class street collection has been developed specifically for everyday life, with designs that are sport-oriented and made of high quality material – and all this is supplemented by “MAGURA Essentials”, which consists of a street collection plus practical and useful accessories.

機能與街頭服飾 – MAGURA & Maloja 聯手出擊

MT7碟煞和Vyron無線伸縮座管的推出，都釋放出一個明確的訊息，那就是瑪古拉宣告進入 - “突破規限、開闢新局”的全新時代。除了榮獲眾多獎項肯定的單車零配件，瑪古拉在今年春季也增加了機能服飾與街頭單品系列，與德國知名服飾品牌Maloja攜手合作，創造多元風格且高質感的服飾系列。

瑪古拉服飾分為兩條產品線，提供超過30樣豐富的產品選擇。“MAGURA by Maloja，雙瑪出任務”，一起為車手打造全新行頭，從輕度越野到耐力賽，推出一系列兼具時尚風格與機能性的車衣褲。另一條支線，主打充滿街頭色彩的日常穿搭風格，同時融入“MAGURA運動元素”，讓熱愛運動休閒風的男女也能輕鬆駕馭。



MAGURA

maloja

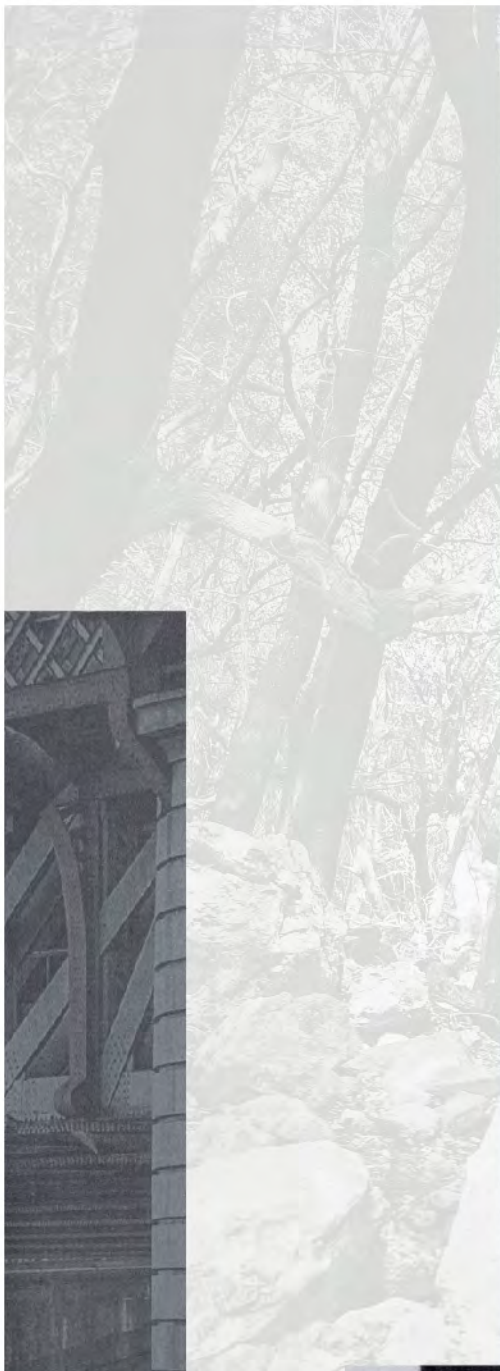

PRODUCT OVERVIEW

RIDE - BIKEWEAR MAGURA by Maloja



MAGURA Gravity Series Short
MAGURA 重力系列短褲



MAGURA Gravity Series Jersey
MAGURA 重力系列 緊身上衣



MAGURA Gravity Series Jersey Longsleeve
MAGURA 重力系列 長袖緊身上衣



MAGURA Trail Series Short
MAGURA 攀岩系列短褲



MAGURA Trail Series Jersey
MAGURA 攀岩系列緊身上衣



MAGURA Multi Sport T-Shirt
MAGURA 多功能運動 T-shirt

RELAX - STREET-WEAR MAGURA by Maloja



MAGURA Stormshell Jacket
MAGURA 防風防潑水夾克



MAGURA Technofleece Jacket
MAGURA 科技纖維夾克



MAGURA Smoke Jersey Longsleeve
MAGURA 煙灰色 長袖上衣



MAGURA Charcoal Polo
MAGURA 炭灰色 Polo衫



MAGURA Charcoal T-Shirt
MAGURA 炭灰色 T-Shirt



MAGURA Patch T-Shirt
MAGURA 雙色 T-shirt



MAGURA Cotton Stretch Pant
MAGURA 彈性棉長褲



MAGURA Beanie
MAGURA 休閒帽

RIDE - BIKEWEAR MAGURA Essentials



MAGURA Competition Series Jersey Longsleeve
MAGURA 競賽系列長袖緊身衣



MAGURA Competition Series Jersey
MAGURA 競賽系列緊身衣



MAGURA Competition Series Bib Short
MAGURA 競賽系列吊帶短褲



RELAX - STREET-WEAR
MAGURA Essentials
休閒-街頭-衣著
MAGURA精選



MAGURA T-Shirt MT7 Black
MAGURA 黑色MT7 T-Shirt



MAGURA T-Shirt MT7 White
MAGURA 白色MT7 T-Shirt



MAGURA T-Shirt MT7 Raceline
MAGURA Raceline MT7 T-Shirt



MAGURA T-Shirt Happy Trails
MAGURA 快樂旅程 T-Shirt



MAGURA T-Shirt The Next Ride
Is Always The Best Ride
MAGURA T恤

ACCESORIES
MAGURA Essentials



MAGURA Flexfit Cap
MAGURA 潮帽



MAGURA Flexfit Cap Kids
MAGURA 潮帽(孩童)



MAGURA Sports Socks Low/Mid
MAGURA 運動襪 短/中筒



MAGURA H.A.D. Headwear Scarf
MAGURA H.A.D 頭巾



MAGURA Shower Towel
MAGURA 浴巾



MAGURA Apron
MAGURA 圍裙



MAGURA Water Bottle
MAGURA 水壺



MAGURA Coffee Cup-To-Go
MAGURA 咖啡隨行杯



MAGURA eLECT Powerbank
MAGURA eLECT 行動電源



MAGURA Multitool M8
MAGURA 多功能工具 M8



SPONSORED RIDERS

贊助車手及車隊



DANNY MACASKILL



BRIAN LOPES



FABIO WIBMER



INTENSE
CYCLES USA

INTENSE FACTORY



CÉDRIC GRACIA



TIBOR SIMAI



LAC BLANC COMMENCAL



PHILIPP FOLTZ / ATLANTIC CYCLING



BERGAMONT H. FACTORY



BRETT TIPPIE



DOROTHEE FLECK



HANNES SLAVIK



CRAFT ROCKY MOUNTAIN



HARALD PHILIPP



CUBE GLOBAL SQUAD

& TEAMS



RADON MAGURA FACTORY



JASPER JAUCH



JORDAN BAUMANN



MAXIMILIAN GAST



KREIDLER WERKSTEAM



DENIS KATZER



MAX SCHUMANN



SOLID-REVERSE FACTORY TEAM



STEFAN HERMANN / MTB ACADEMY



SABINE SPITZ



MARCUS KLAUSMANN



STEFAN SCHLIE



MORGAN SUCH



TINO KÄSSNER



YANNICK GRANIERI

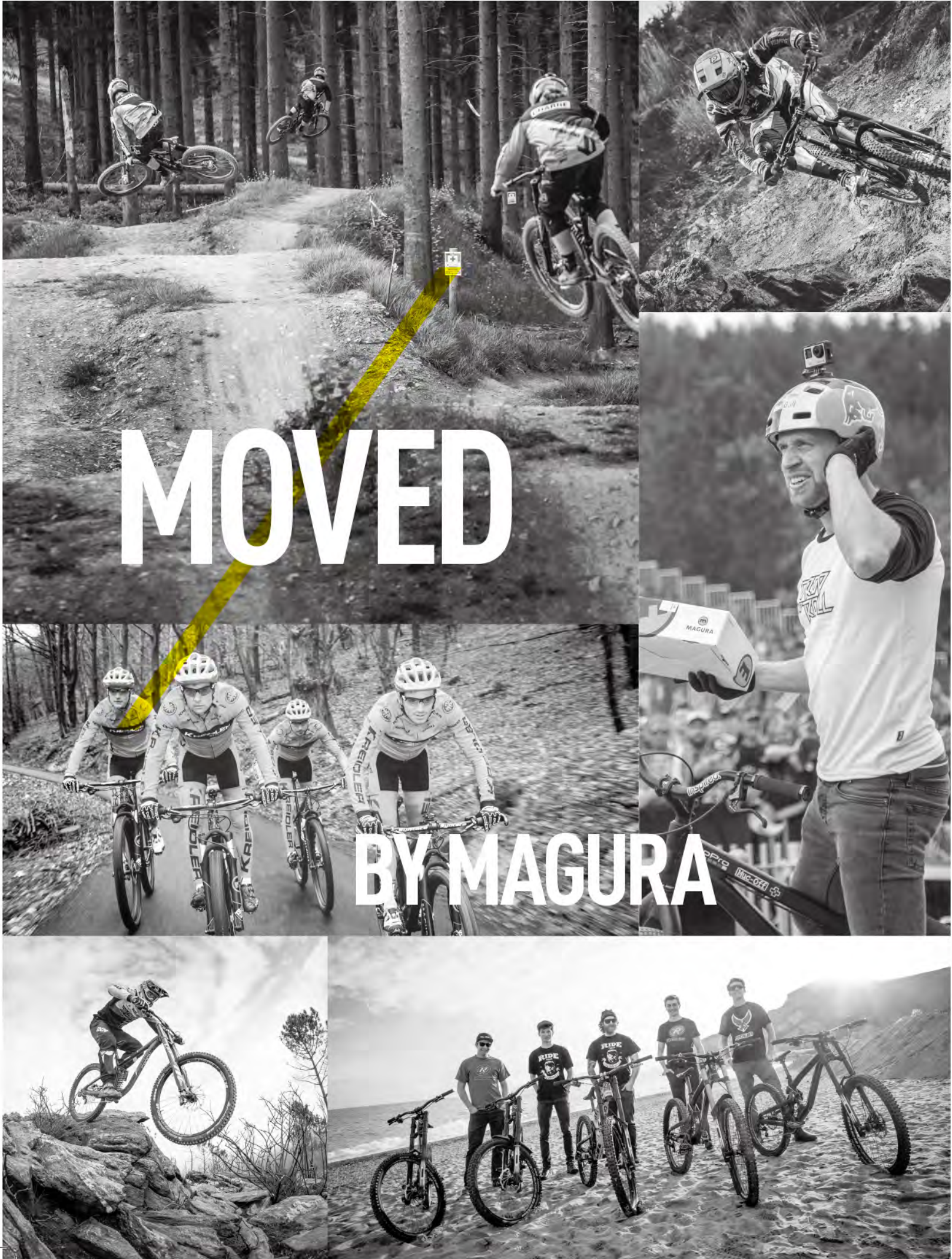

MOVED

BY MAGURA